



VESTIL MANUFACTURING CORP.

2999 North Wayne Street, P.O. Box 507, Angola, IN 46703

Telephone: (260) 665-7586 -or- Toll Free (800) 348-0868

Fax: (260) 665-1339

Web: www.vestilmfg.com e-mail: info@vestil.com

OROAD-400 Traction Drive Electric Cart

Use & Maintenance Manual



Receiving instructions:

After delivery, remove the packaging from the product. Inspect the product closely to determine whether it sustained damage during transport. If damage is discovered, record a complete description of it on the bill of lading. If the product is undamaged, discard the packaging.

NOTE:

The end-user is solely responsible for confirming that product design, installation, use, and maintenance comply with laws, regulations, codes, and mandatory standards applied where the product is used.

Table of Contents

Safety Principles.....	2
Hazards of Improper Use.....	2
Product specifications.....	3
Parts List.....	6
Operation instructions.....	7
Perimeter guard adj. & battery access.....	7
Battery charger use and operation.....	8
Maintenance.....	9
Limited Warranty.....	10

Table of Figures

FIG. 1 "Right side view".....	3
FIG. 2 "Rear view (operator end)".....	3
FIG. 3 "Front view (loading end)".....	3
FIG. 4 "Main features".....	4
FIG. 5 "Operation controls".....	4
FIG. 6 "Operation control panel".....	4
FIG. 7 "Exploded parts diagram".....	5
FIG. 8A "Raising the deck & adjusting guards".....	7
FIG. 8B "Adjustment range of perimeter guards".....	7
FIG. 8C "Threaded knob".....	7

Signal Words:

This manual uses SIGNAL WORDS to call attention to uses of this product that are likely to result in personal injuries or property damage. The signal words used in this manual appear below along with their definitions.



Identifies a hazardous situation which, if not avoided, WILL result in DEATH or SERIOUS INJURY. Use of this signal word is limited to the most extreme situations.



Identifies a hazardous situation which, if not avoided, COULD result in DEATH or SERIOUS INJURY.



Indicates a hazardous situation which, if not avoided, COULD result in MINOR or MODERATE injury.



Identifies practices likely to result in product/property damage, such as operation that might damage the cart.

Hazards of Improper Use:

Failure to read and understand the instructions included in this manual BEFORE using or maintaining the platform cart constitutes misuse of the product. Study the entire manual before using or maintaining the product for the first time, and subsequently as necessary to refresh your understanding. DO NOT attempt to resolve any problem(s) with the device unless you are both authorized to do so and certain that it will be safe to use afterwards.



If this product is used improperly or carelessly, the operator and/or bystander(s) might sustain serious personal injuries. To reduce the likelihood of injury:

- When not in use, store the cart in an indoor, dry location. DO NOT expose the electrical system to moisture (rain, snow, etc.).
- DO NOT remove or obscure any label. Verify the placement and legibility all labels. DO NOT use the cart UNLESS all labels are attached and readable.
- DO NOT attempt to transport unbalanced loads with the cart. Only use the cart to transport stable loads. Secure the load to the deck with straps, if necessary to prevent the load from shifting during transport.
- DO NOT exceed the load rating. ALWAYS make sure that the load weighs **no more than** the rated load of the coil hook. Rated load varies with the supporting surface (ground/floor): 1) Maximum rated load when used on smooth, level *improved* surfaces = 600 pounds (273kg); 2) when used on level, *unimproved* surfaces (e.g. gravel, dirt) = 500 pounds (227¼kg); and 3) inclined/sloped surfaces UP TO a maximum of 13 degrees = 400 pounds (182kg).
- DO NOT ride on the cart or allows other person(s) to do so.
- Inspect the cart prior to each use. DO NOT use the cart if it is noticeably AND dangerously damaged. Examples of noticeable damage include, but are not limited to punctured tire(s), non-functioning brake lever, cut or exposed electrical wires.
- While traveling up or down an incline, DO NOT change the speed setting. Always traverse the whole incline in the same speed setting, because changing the speed setting might cause the cart might roll down the incline in an uncontrolled manner.
- ALWAYS start the cart with the speed selection knob in the “Stop” position (see p. 4). ALWAYS return the speed selection knob to “Stop” when the cart is not in use.
- Improperly recharging the batteries might either cause the batteries to explode or result in battery damage. To properly recharge the batteries: 1) Shut off the power (turn the switch key to “off”); 2) connect the AC extension cord of the charger to the outlet of a nearby power supply (the charger will automatically turn on and it will run at a rate that matches the requirements of the batteries.) When the batteries are fully charged, the charger will only supply enough current to maintain charge; 3) disconnect the AC plug from the power supply once charging is complete.
- DO NOT leave a loaded cart unattended. Always unload the cart BEFORE leaving the cart unattended.

FIG. 1: Side view

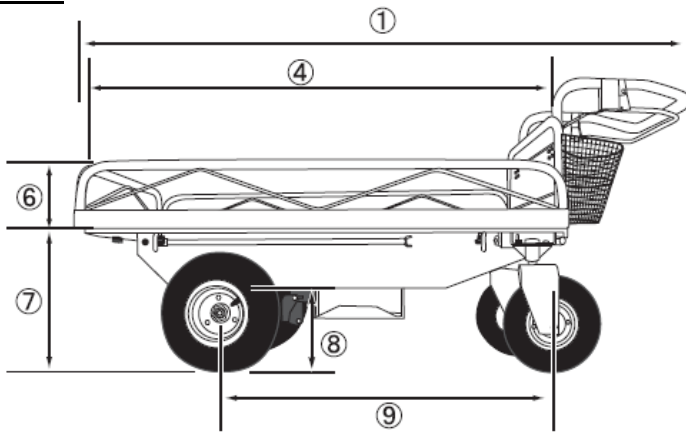

Product specifications:

Uniform static capacity in pounds (kg)	Improved surfaces	Unimproved surfaces	Inclined surfaces (max. 13% grade)
	600 (273kg)	500 (227kg)	400 (182kg)
Net weight in pounds (kg)	323 (~147kg)		
Deck dimensions in inches (cm)	31½ x 52½ x 15¾ (80 x 133.4 x 40)cm		
Wheel dimensions in inches (cm)	Front wheels		Rear wheels
	3½ x 11 (9 x 28)cm		6 x 14 (15¼ x 35.6)cm
Battery specifications (each cart has 2 batteries)	12V; 40A·h Power sufficient for 4hours use		
Battery charger	24V (AC)		
Motor specifications	600W; 24V (DC)		
Brakes	Electrical and mechanical		
Drive mode	Differential gears: High; Low; & Reverse		

Measurement	Dimension
1	72in. 183cm
2	33.5in. 85cm
3	37.5in. 95.25cm
4	52in. 133cm
5	31.5in. 80cm
6	7.3in. 18.5cm
7	15.75in. 40cm
8	3in. 7.5cm
9	36.8in. 93.5cm
10	25.6in. 65cm
11	24in. 61cm

FIG. 2: Rear view (operator end)

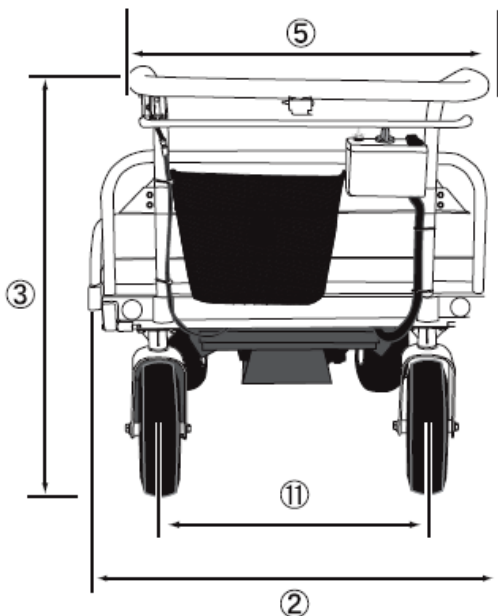

FIG. 3: Front view (loading end)

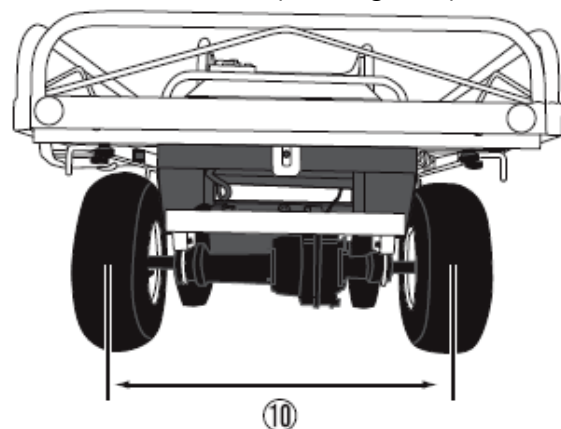

Fig. 4: Main features

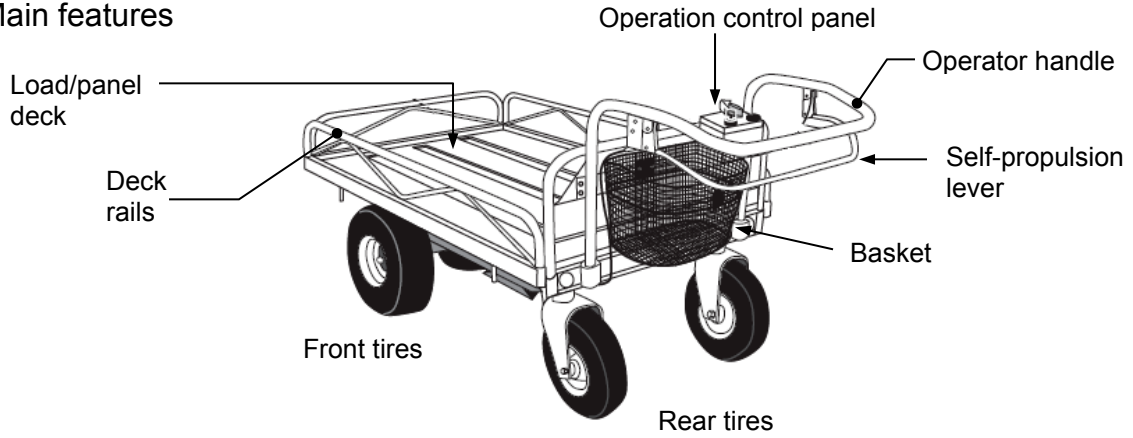

Fig. 5: Operator controls

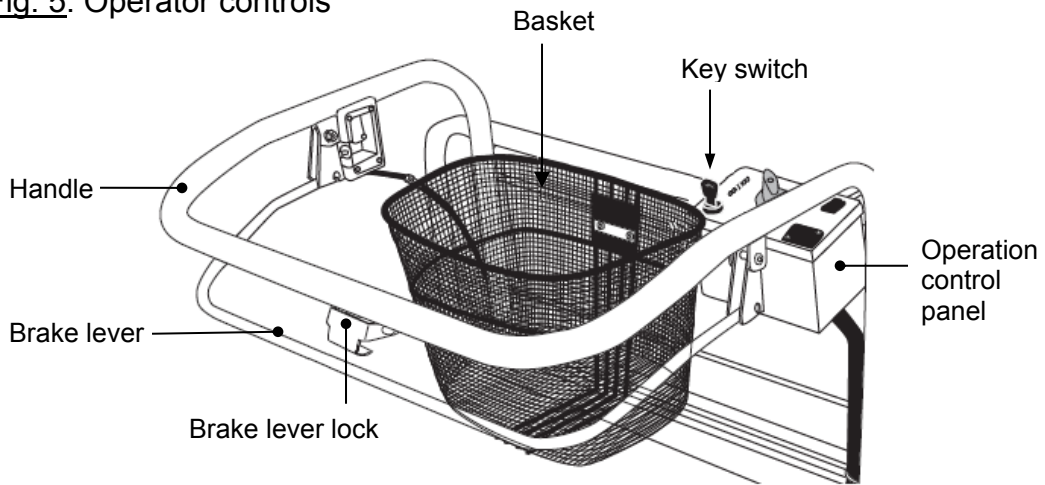
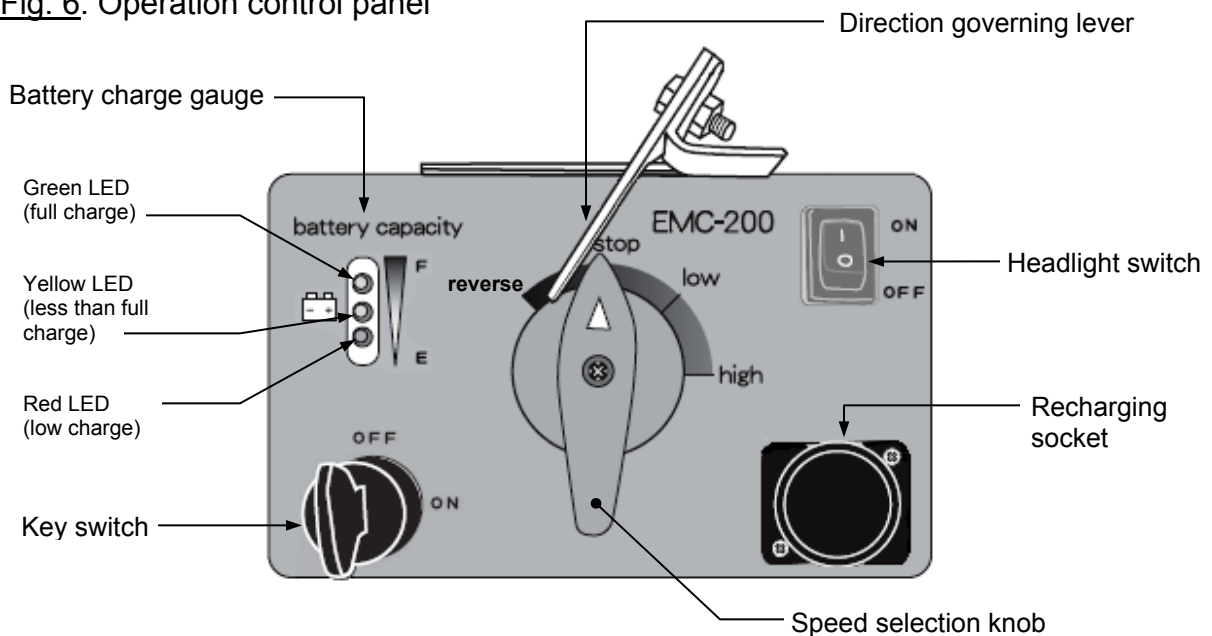
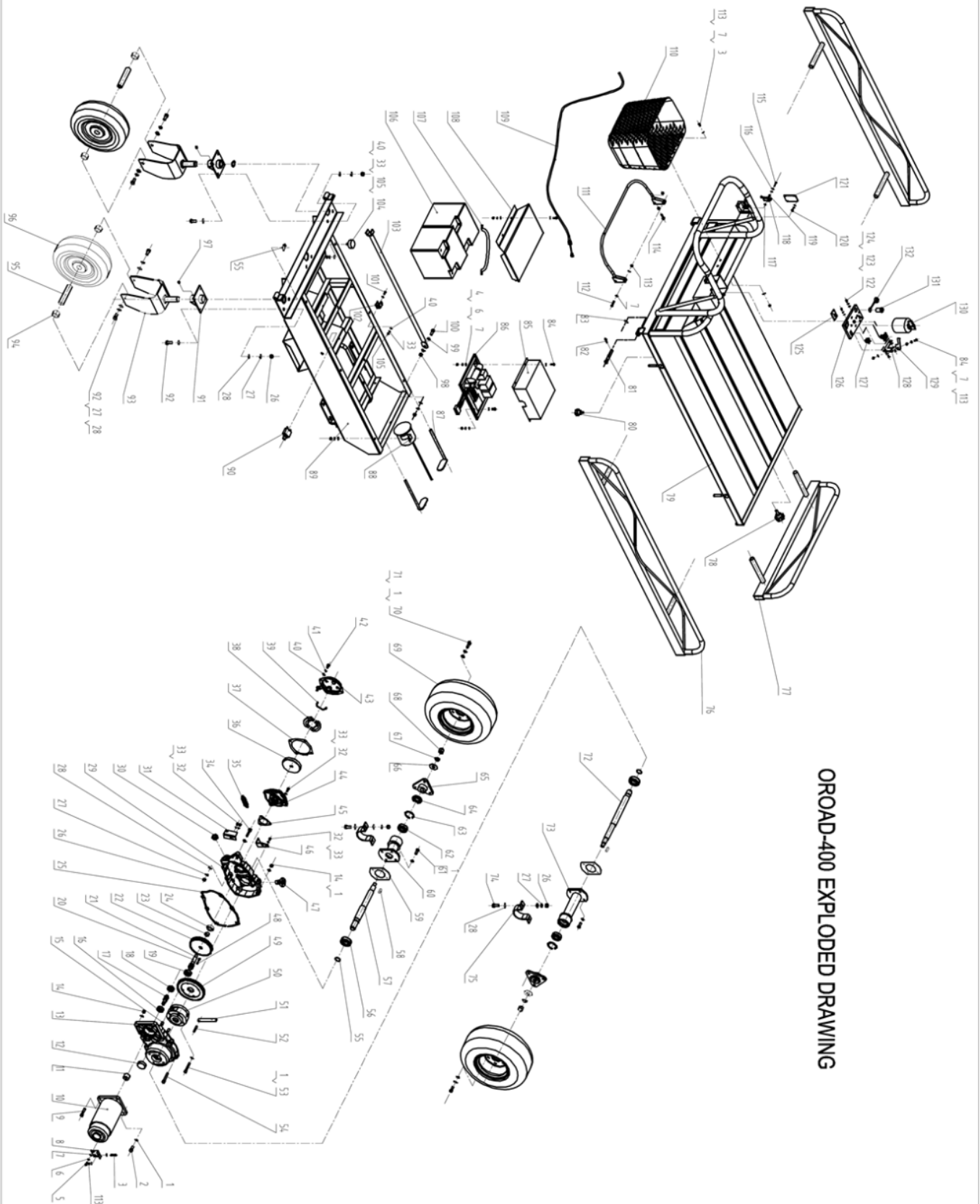

Fig. 6: Operation control panel



OROAD-400 Exploded Parts Diagram



OROAD-400 EXPLODED DRAWING

DC CARRY TRUCK OROAD-400 PARTS LIST

Item	Part Name	Qty.	Item	Part Name	Qty.	Item	Part Name	Qty.
1	Gasket Φ8	33	46	Break pole	1	91	Steering Bracket	2
2	Bolt M8X25	2	47	breath device	1	92	Bolt M10X25	12
3	Screw M5X14	3	48	Shaft Key 5X14	1	93	Steering Bracket	2
4	Nut M5	4	49	II Gear	1	94	Sleeve	4
5	Screw M5X8	2	50	Differential shell	1	95	Core Shaft	2
6	Gasket Φ5	9	51	Pin Shaft	1	96	Steering Tire 4.1/3.5-5	2
7	Gasket Φ5	29	52	Pin 5X30	1	97	Oil Cup M6	2
8	Motor Bracket	1	53	Bolt M8X55	2	98	Nut M8	1
9	Bolt M8X40	2	54	Bolt M8X55	6	99	Spring 18	2
10	24VDC Motor	1	55	Shaft Ring Φ25	4	100	Bolt M8X30	1
11	Connect Sleeve	1	56	Bearing 6205	2	101	Screw M6X16	1
12	Rubber seat 35X7	1	57	Short Shaft	1	102	Bracket	1
13	Right Cover	1	58	Key 6X32	2	103	Rod	1
14	Nut M8	8	59	Sealing - I	1	104	Gasket	6
15	Shaft Sleeve G10X8.5X15	2	60	Short Shaft Bracket	1	105	Nut M6	7
16	Bearing 6201N	1	61	Screw M8X20	8	106	Battery 12V/40AH	2
17	I Gear Shaft	1	62	Bearing 6005	2	107	Battery Cable	1
18	Bearing 6201	1	63	Ring	2	108	Battery Cover	1
19	Bearing 6202N	1	64	Sealing 25X47X8	2	109	Brake Line	1
20	II Gear Shaft	1	65	Flange	1	110	basket	1
21	Shaft Key 4X12	1	66	Gasket Φ14	2	111	Brake handle	1
22	I Gear	1	67	Gasket Φ14	1	112	Screw M5X30	2
23	Location Sleeve	1	68	Nut M14	2	113	Nut M5	6
24	Bearing 6302	1	69	Drive Wheel 145/70-6	2	114	Bolt M6X30	1
25	Sealing II	1	70	Bolt M8X20	6	115	Screw M3X25	2
26	Nut M10	11	71	Gasket Φ8	10	116	Gasket Φ3	6
27	Gasket Φ10	15	72	Long Shaft	1	117	Nut M3	3
28	Gasket Φ10	27	73	Long Shaft Bracket	1	118	Switch	1
29	Left Cover	1	74	Bolt M10X30	4	119	Switch Pipe	
30	Hole M20X1.5	1	75	bottom plate	2	120	Screw M3X8	4
31	Break Line Bracket	1	76	side frame	2	121	Cover	1
32	Screw M6X16	6	77	front frame	1	122	Screw M4X12	4
33	Gasket Φ6	13	78	locking bolt M10	1	123	Gasket Φ4	4
34	Bolt M10X40	1	79	carriage subassembly	1	124	Gasket Φ4	4
35	Spring	1	80	locking bolt M6	6	125	Battery Panel	1
36	Brake Disc	1	81	Pin Shaft B12X80	2	126	Control Panel	1
37	Brake Gasket		82	Pin 4X24	2	127	Switch	1
38	Brake Disc others	2	83	Gasket Φ12	2	128	Anti-Back Bracket	1
39	U Wire	1	84	Screw M5X16	5	129	Anti-Back Bracket	1
40	Gasket Φ6	12	85	Control Box	1	130	Switch	1
41	Gasket Φ6	4	86	Control Parts	1	131	Power Switch Locker	1
42	Bolt M6X14-4.8	4	87	24V LED Lamp	2	132	Key Hole Anti-Water Cover	1
43	Break Cover	1	88	24VDC buzzer	1			
44	Break Seat	1	89	bodywork	1			
45	Break Seat Gasket	1	90	Overload Protection Device	1			

Part # 106 Battery Size(WxLxH):
L197mm xW165mm xH170mm

Drive wheel assembly gear oil type:85W/90GL-4

Oil needed for gear box: 300cc (11 ounces)

Operation:

WARNING Turn the speed selection knob to “Stop” before the cart is left unattended.

The speed control knob should already be in the “Stop” position, but if not, turn the knob to “Stop”. Insert a key (two keys are enclosed inside packaging with this manual) into the slot in the key switch, and turn the key to the “On” position. The battery charge/capacity display (see FIG. 6) will illuminate when system power is turned on (see Fig. 6 on p. 3). The red LED will flash if the batteries require recharging.

Select the desired speed setting: low or high with the speed selection knob. To propel the cart, grasp the handle and press the self-propulsion lever and handle together. *Slowly* and gradually release the lever to stop the cart

The “Direction governing lever” prevents accidental operation in reverse. To use the lever, pivot it over the operation control panel as shown in FIG. 6. Always use the lever when operating the cart in forward (low or high). To operate the cart in reverse, flip up the lever, turn the speed selection knob to “Reverse”, and then press the self-propulsion lever and handle together.

Perimeter Guard Adjustment & Battery Access:

Arrows show the positions of threaded knobs used to secure the perimeter guards to the deck. To adjust the position of a perimeter guard, loosen the appropriate knobs (indicated by arrows in the drawing below and shown in “Threaded knob” below); then pull the guard away from, or push it towards, the deck (See “Adjustment range of perimeter guards”). After adjusting the guard, tighten the knobs to secure it in the adjusted position.

FIG. 8A: Raising the deck & adjusting guards

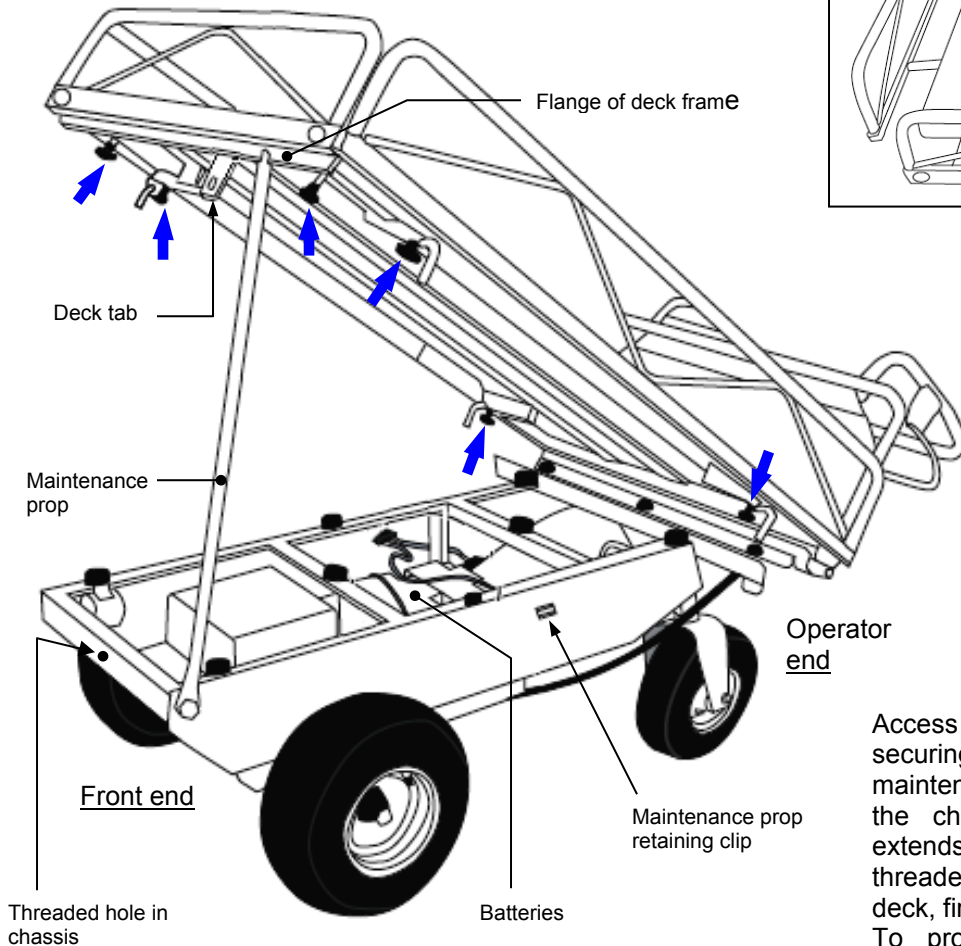

FIG. 8B: Adjustment range of perimeter guards

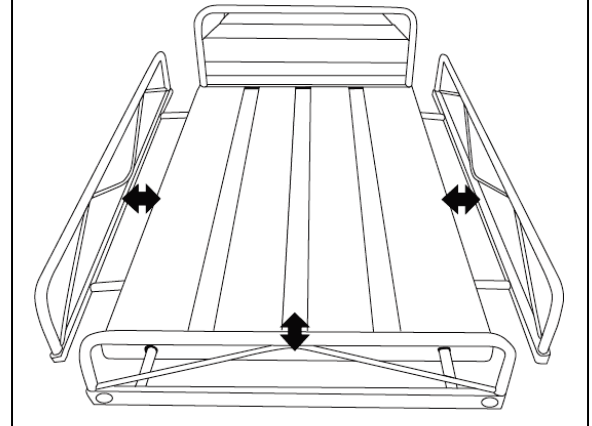
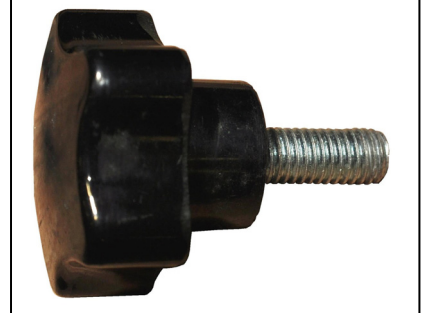

FIG. 8C: Threaded knob



Access the batteries by lifting the deck and securing it in the elevated position with the maintenance prop. The deck is secured to the chassis with a threaded knob that extends through the deck tab and into a threaded hole in the chassis. To raise the deck, first remove this knob.

To properly engage the deck with the maintenance prop, the flange of the deck frame should fit inside the bracket at the end of the maintenance prop.

Battery charger use and operation:

- Working with or near lead acid batteries is dangerous. Batteries contain sulfuric acid and produce explosive gases. A battery explosion could result in loss of eyesight and/or serious burns.
- Do not smoke, or allow a spark or flame, near batteries. Only charge the batteries in a clean, dry, and well-ventilated location. Do not lay tools or metallic items on top of any battery. All repairs to a battery must be made by experienced and qualified personnel.
- Before working with batteries, remove personal items such as rings, bracelets, necklaces, and watches. Batteries produce sufficient energy to weld jewelry to metal, and to cause severe burns.
- Always have fresh water and soap nearby in case battery acid contacts skin, clothing, or eyes.
- Operating the cart with a low battery voltage can cause premature motor contact failure.
- Do not expose the cart or charger to moisture (rain, snow, sleet, etc.).
- Replace defective cords or wires immediately.
- Check the water level of the batteries frequently.

The battery charger consists of 2 parts: 1) the charger; and 2) a power cord that plugs into the charger.

To charge the batteries, plug the female end of the power cord into the charger; connect the charger plug to the charger socket on the operation control panel; plug the male end of the power cord into a (standard) 115V wall receptacle; and then press the power switch on the charger.

NOTICE Do not connect the charger to an extension cord unless it is unavoidable. If an extension cord is necessary, it should be as short as possible with a large cross-section. A cord of small cross-section and/or longer length will decrease the output of the charger, and consequently will increase the time necessary to charge the batteries. This can also cause the 115V cord to overheat.

When properly connected, a series of 3 LED's indicates the status of current flowing to the battery, as follows: Power LED is always green when charger is plugged in.

The status light is as follows:

Red only – the charger is providing full output to the battery.

Yellow – the charger is “topping off” the battery.

Green – the charger is providing a “float,” or maintenance, charge.

Unplug the charger before using the cart.

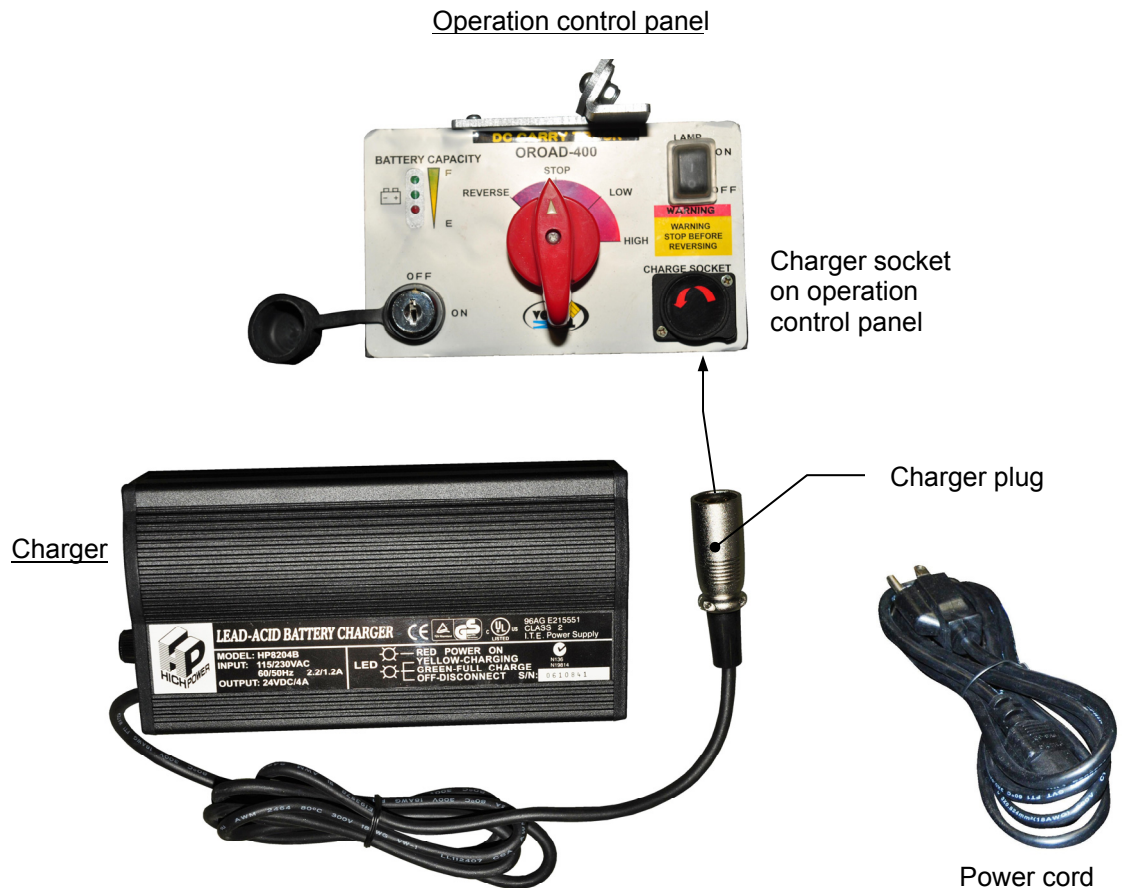

Maintenance: Turn off the power and restrain the unit using chocks or other restraining devices, before working on the unit.

- Only trained and authorized personnel should be permitted to maintain, repair, and inspect the unit.
- Keep usage area dry, clean, and well ventilated.
- To avoid fire hazards, have fire protection equipment present at all times during any maintenance or repair. Do not use open pans or containers of flammable fluids.
- Safety devices shall be inspected at monthly intervals and maintained to a safe operating condition. A maintenance log must be kept.
- Electrical components shall be maintained and inspected for safe operation.
- The battery electrolyte level should be checked before charging the battery. The level should be maintained at 1/2 inch above the plates. If the level is low, add approved water before charging. Do not overfill. It is not necessary to charge the battery every day if there is more than 1/3 left, however the battery should be charged at least once a week.
- Disconnect batteries before working with the electrical system.
- When checking the hydraulic fluid level, make certain that the unit is fully lowered and on a level floor. Remove the filler cap and check the level of the fluid. Use a top quality hydraulic fluid. Do not use hydraulic brake fluid.
- Before leaving the unit, stop the unit, lower the forks fully, turn off the power, and remove the key.

LIMITED WARRANTY

Vestil Manufacturing Corporation ("Vestil") warrants this product to be free of defects in material and workmanship during the warranty period. *Our warranty obligation is to provide a replacement for a defective original part if the part is covered by the warranty, after we receive a proper request from the warrantee (you) for warranty service.*

Who may request service?

Only a warrantee may request service. *You are a warrantee if* you purchased the product from Vestil or from an authorized distributor AND Vestil has been fully paid.

What is an "original part"?

An original part is a part used to make the product as shipped to the warrantee.

What is a "proper request"?

A request for warranty service is proper if Vestil receives: 1) a photocopy of the Customer Invoice that displays the shipping date; AND 2) a written request for warranty service including your name and phone number. Send requests by any of the following methods:

Mail
Vestil Manufacturing Corporation
2999 North Wayne Street, PO Box 507
Angola, IN 46703

Fax
(260) 665-1339
Phone
(260) 665-7586

Email
sales@vestil.com

In the written request, list the parts believed to be defective and include the address where replacements should be delivered.

What is covered under the warranty?

After Vestil receives your request for warranty service, an authorized representative will contact you to determine whether your claim is covered by the warranty. Before providing warranty service, Vestil may require you to send the entire product, or just the defective part or parts, to its facility in Angola, IN. The warranty covers defects in the following original dynamic components: motors, hydraulic pumps, electronic controllers, switches and cylinders. It also covers defects in original parts that wear under normal usage conditions ("wearing parts"), such as bearings, hoses, wheels, seals, brushes, and batteries.

How long is the warranty period?

The warranty period for original components is 90 days. The warranty period begins on the date when Vestil ships the product to the warrantee. If the product was purchased from an authorized distributor, the period begins when the distributor ships the product. Vestil may extend the warranty period for products shipped from authorized distributors by up to 30 days to account for shipping time.

If a defective part is covered by the warranty, what will Vestil do to correct the problem?

Vestil will provide an appropriate replacement for any covered part. An authorized representative of Vestil will contact you to discuss your claim.

What is not covered by the warranty?

1. Labor;
2. Freight;
3. Occurrence of any of the following, which automatically voids the warranty:
 - Product misuse;
 - Negligent operation or repair;
 - Corrosion or use in corrosive conditions;
 - Inadequate or improper maintenance;
 - Damage sustained during shipping;
 - Accidents involving the product;
 - Unauthorized modifications: DO NOT modify the product IN ANY WAY without first receiving written authorization from Vestil. Modification(s) might make the product unsafe to use or might cause excessive and/or abnormal wear.

Do any other warranties apply to the product?

Vestil Manufacturing Corp. makes no other express warranties. All implied warranties are disclaimed to the extent allowed by law. Any implied warranty not disclaimed is limited in scope to the terms of this Limited Warranty.

