

Instruction Manual

ELECTRIC ORDER PICKER



Note: The Owner/Operator must read carefully and understand all the information presented here before operation.

Content

1. Lifting & Lowering the table.....	2
2. Loading Safety Valve	2
3. Loading Capacity Chart.....	2
4. Battery Recharge.....	4
5. Electric Circuit Diagram.....	4
6. Exploded View & Part List.....	5

THANK YOU FOR USING THIS ELECTRIC ORDER PICKER. FOR YOUR SAFETY AND CORRECT OPERATION, PLEASE CAREFULLY READ THIS INSTRUCTION BEFORE USING IT.

NOTE: All of the information reported herein is based on data available at the moment of printing. The factory reserves the right to modify its own products at any moment without notice and incurring in any sanction. So it is suggested to always verify possible updates.

1. LIFTING & LOWERING THE TABLE

To lift the table, push the TWO 'UP' buttons at both left and right handles at the same time.

To lower the table, push the TWO 'DOWN' buttons at both left and right handles at the same time.

2. LOADING SAFETY VALVE

If the table is overloaded, loading safety valve is automatic opened to stop lifting.



CAUTION! The max. loading capacity is 200Kg (=440LBS) include operator.

3. LOADING CAPACITY CHART

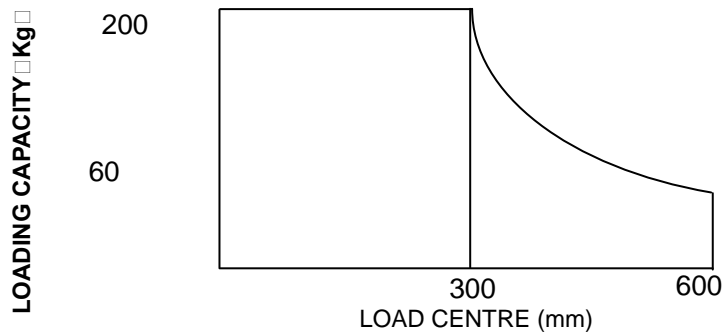

- ✧ The max. loading capacity is 200Kg including operator. Do not overload.
- ✧ Before lifting or lowering the table, make sure to brake the picker.
- ✧ Before moving the picker, make sure that the table be set at lower position.
- ✧ Ensure the balance of loading. Do not load partially or concentrically.
- ✧ Store the picker indoor and keep away from rain, water, or acid before storing the picker, turn off the switch.
- ✧ Rusted or damaged chain may cause breaking off. Stop operating and replace it.

Ride on the table properly and close the door before lifting



CAUTION!

If operating the picker improperly, a person may be injured. Operate properly according to following instruction.

- ✧ Do not use the picker on a sloping or soft ground.
- ✧ Do not enter underneath the table.
- ✧ Do not ride on the table



CAUTION!

The max. loading capacity is 200Kg (=440LBS)include operator.

4. BATTERY RECHARGE



CAUTION!

When recharging the battery, keep away from fire. The first recharge time must be more than 10 hours.



CAUTION!

When the voltage is reduced to 10.5 volt, the battery must be recharged immediately.

5. ELECTRIC CIRCUIT DIAGRAM

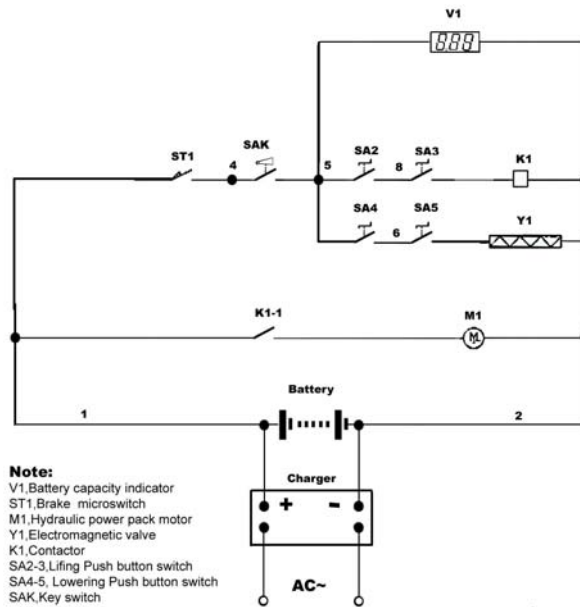

Note:
 V1, Battery capacity indicator
 ST1, Brake microswitch
 M1, Hydraulic power pack motor
 Y1, Electromagnetic valve
 K1, Contactor
 SA2-3, Lifting Push button switch
 SA4-5, Lowering Push button switch
 SAK, Key switch

6. EXPLODED VIEW & PART LIST

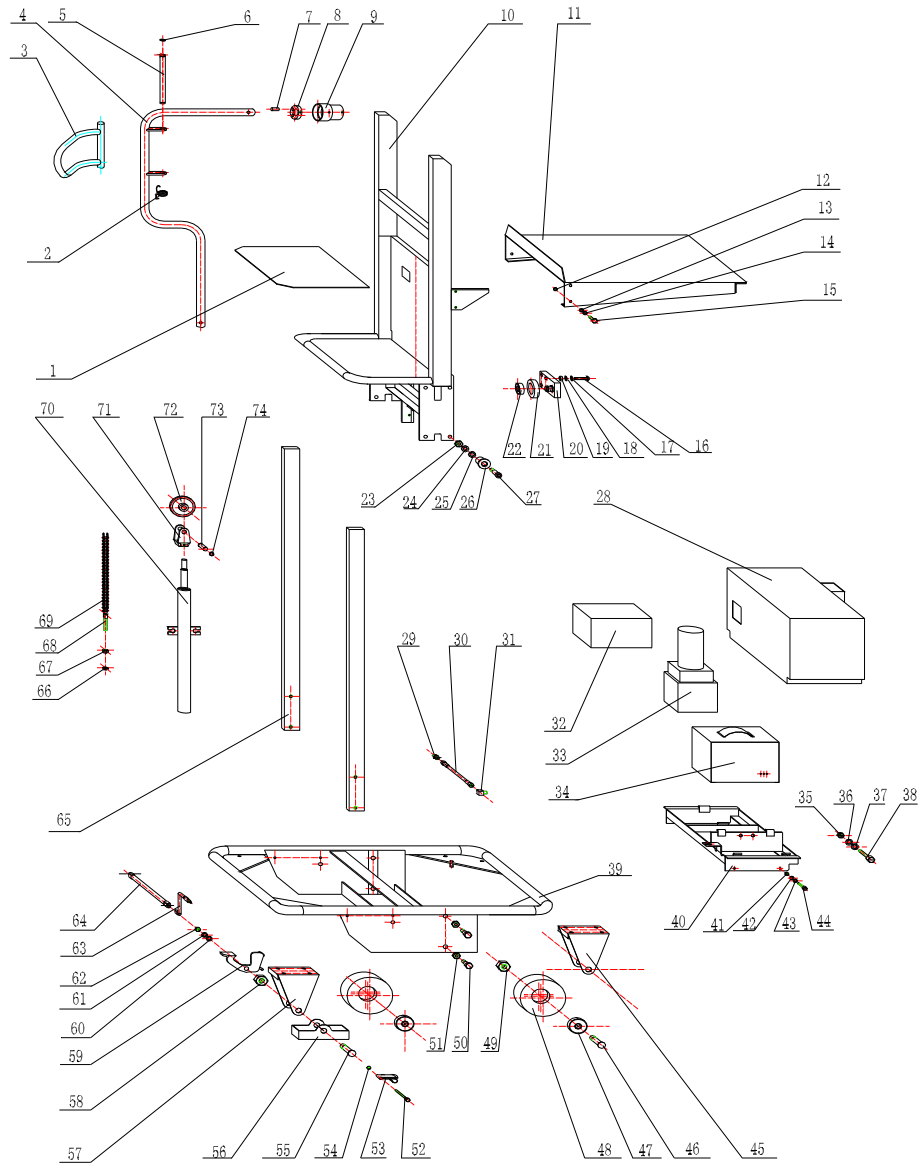

No.	Description	Qty	No.	Description	Qty
1	Cushion	1	25	Spring Washer 12	8
2	Spring	2	26	Roller	8
3	Safety Handrail	2	27	Roller axle	8
4	Handle	2	28	Pump cover	1
5	Pin Axle	2	29	Right Angle Joint	1
6	Spacing Retainer 12	4	30	Oil hose	1
7	Pushbutton	4	31	Right angle Joint	1
8	Pushbutton Mount	2	32	Battery	1
9	Pushbutton Case	2	33	Power unit pack	1
10	Upper frame	1	34	Charger	1
11	Platform	1	35	Nut M10	2
12	Locknut M8	4	36	Washer 10	2
13	Washer 8	4	37	Spring Washer 10	2
14	Spring Washer 8	4	38	Bolt M10x20	2
15	Bolt M8x26	4	39	Base	1
16	Bolt M8x30	16	40	Power Unit Base	1
17	Spring Washer 8	16	41	Nut 6	4
18	Washer 8	16	42	Spring Washer 6	4
19	Locknut M8	16	43	Washer 6	4
20	Fixed plate	4	44	Screw M6	4
21	Wheel	4	45	Frame of Universal Wheel	4
22	Bearing	4	46	Pin of wheel	4

No.	Description	Qty	No.	Description	Qty
23	Locknut M12	8	47	Bearing	4
24	Washer 12	8	48	Wheel	4
49	Nut M20	2	62	Nut 12	2
50	Bolt of pole	4	63	Brake Pole	2
51	Spring washer 14	4	64	Connecting Pole	1
52	Nut M6x70	2	65	Support Pole	2
53	Brake spring board	2	66	Thin Nut M10	2
54	Nut M6	2	67	Nut M10	2
55	Pin axle wheel	2	68	Screw M10	2
56	Safety cover	2	69	Chain	1
57	Frame of Universal Wheel	2	70	Oil cylinder	1
58	Thin Nut M20	2	71	Chain wheel base	1
59	Brake Pole for recovery	1	72	Chain wheel	1
60	Spring Washer 12	2	73	Chain wheel axle	1
61	Washer 12	2	74	Spacing retainer 12	2

ELECTRIC ORDER PICKER - EOP-440

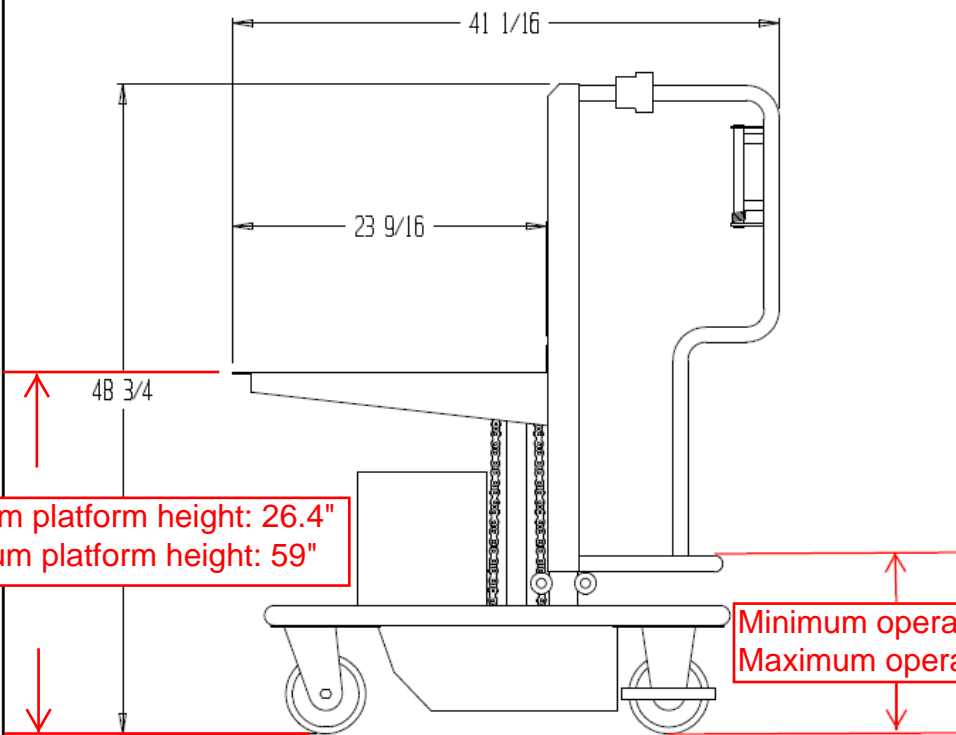
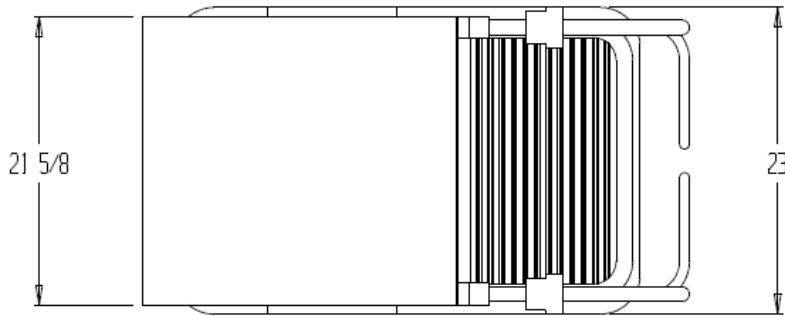

Minimum platform height: 26.4"
Maximum platform height: 59"

Minimum operator's platform height: 11 13/16"
Maximum operator's platform height: 44 1/2"

STANDARD FEATURES

MODEL NUMBER: EOP-440

CAPACITY: 440 LBS

OVERALL WIDTH: 23"

OVERALL LENGTH: 41 1/16"

OVERALL HEIGHT: 48 3/4"

SERVICE RANGE: 26" TO 59"

PLATFORM SIZE: 21 5/8" x 23 9/16"

(2) - 6" x 1 1/2" SWIVEL CASTERS IN FRONT

(2) - 6" x 1 1/2" RIGID CASTERS IN BACK