

## **EMHC-2860-2 (ELECTRIC MATERIAL HANDLING CART)**

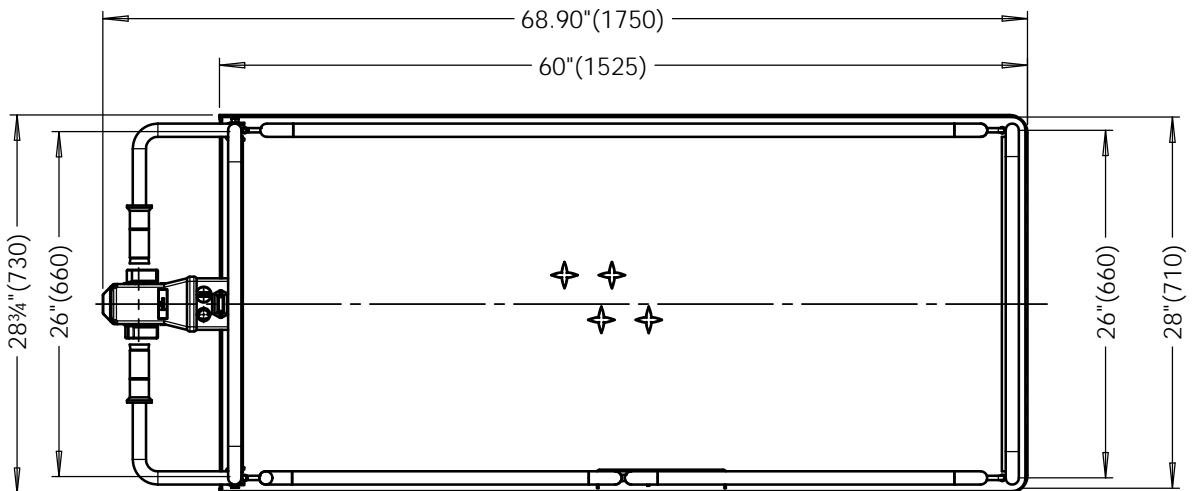
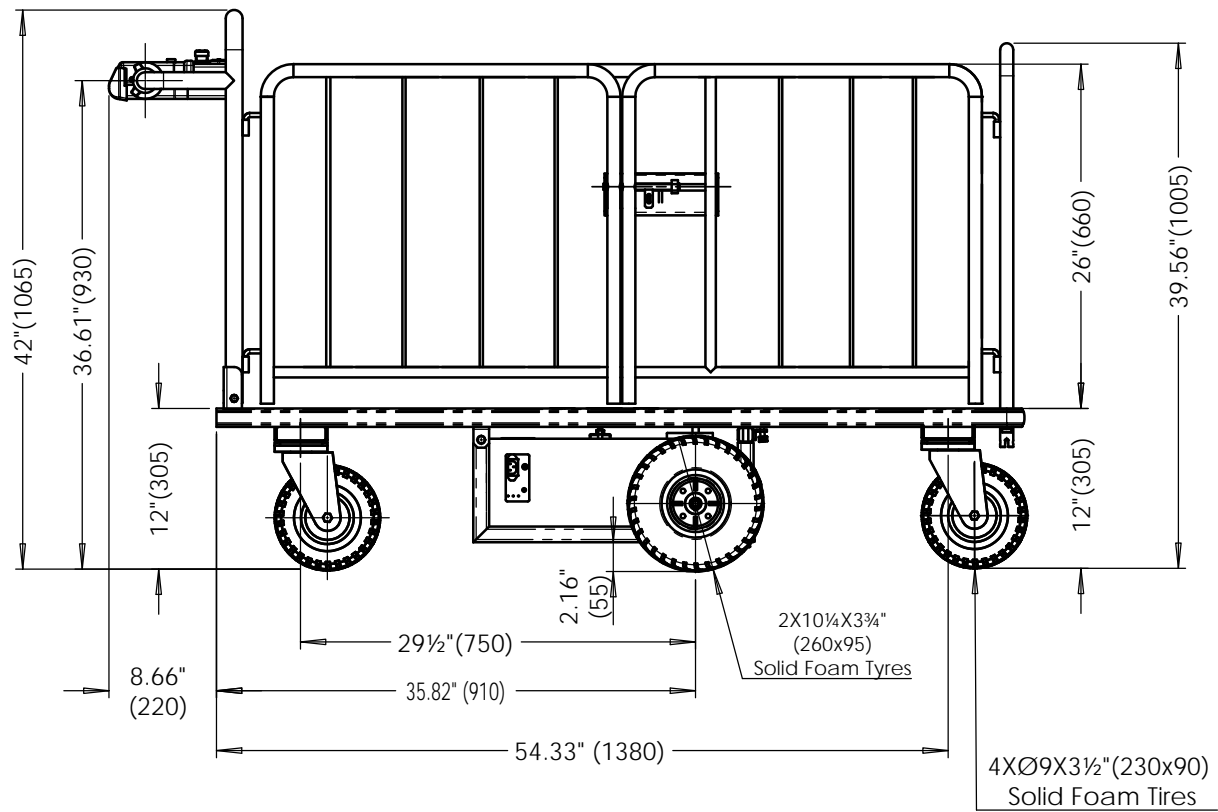

**Specifications:**

Capacity: 1,500 lbs (680 kgs.)  
 Drive Axle: C04II-24/800  
 Gear Ratio: 40:1  
 Drive Motor: DC24V/800W  
 Controller: Curtis 1228 - 2411  
 Battery: 2x12V/45Ah (AGM)  
 Charger: 24V/8Amps - (4amps/bank)  
 Loaded Speed: 2.8m/h  
 Unloaded Speed: 3.4m/h

Model:	EMHC-2860-2
Description: Electric Material Handling Cart	
Design: T.M.	Date: 08/07/2017