

EMHC-2860-1 (ELECTRIC MATERIAL HANDLING CART)

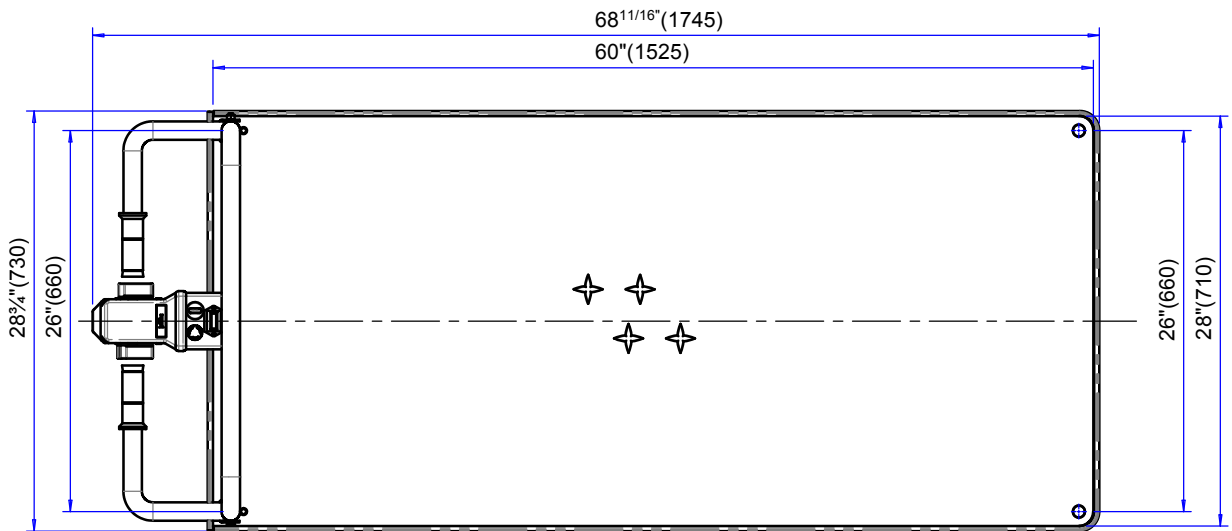
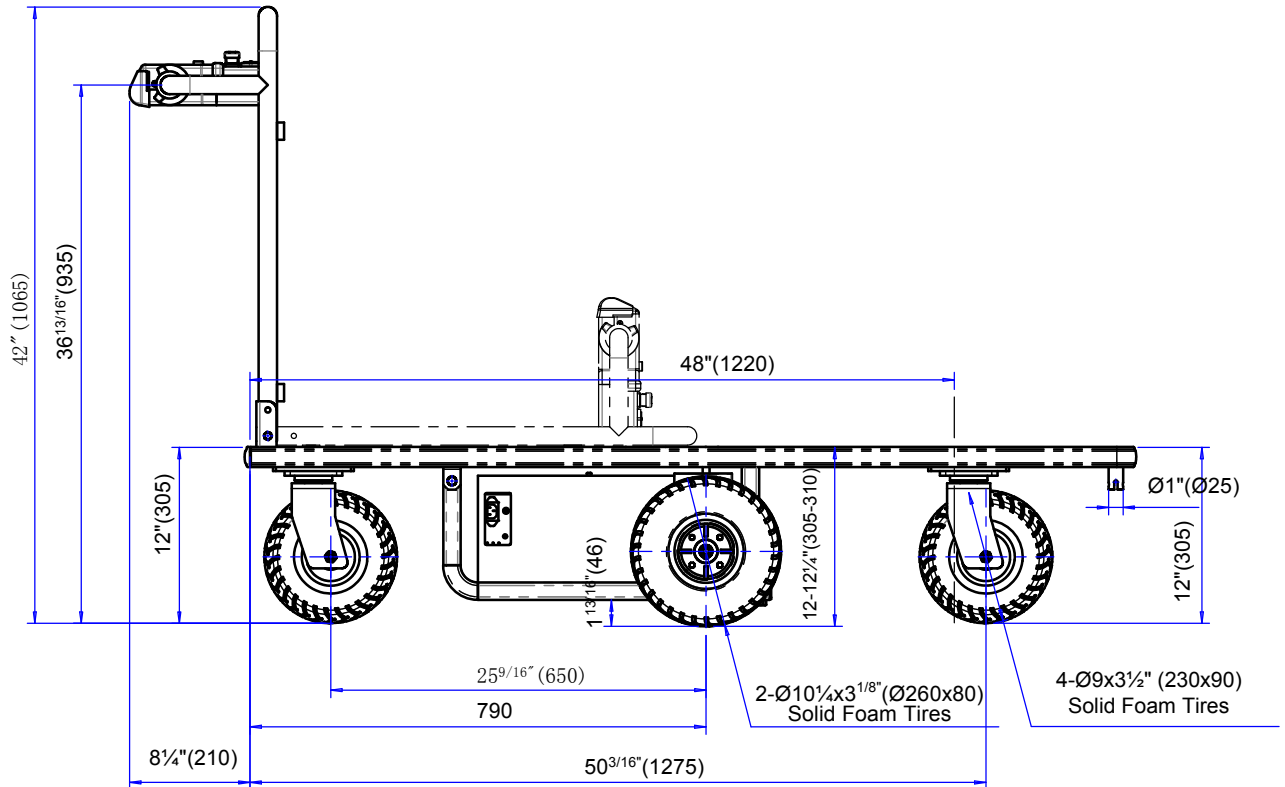

Specifications:

- Capacity: 1,500 lbs (680 kgs.) Drive
- Axle: C04II-24/800
- Gear Ratio: 40:1
- Drive Motor: DC24V/800W
- Controller: Curtis 1228 - 2411
- Battery: 2x12V/45Ah (AGM)
- Charger: 24V/8Amps - (4amps/bank)
- Loaded Speed: 2.8m/h
- Unloaded Speed: 3.4m/h

| | |
|--|------------------|
| Model: EMHC-2860-1 | |
| Description: Electric Material Handling Cart | |
| Design: T.M. | Date: 08/29/2015 |