

# ELECTRIC HYDRAULIC LIFT TABLE PORTABLE - EHLTP-3064-3-60-D2

APPROX WEIGHT: 1112 lbs.  
DOES NOT INCLUDE WEIGHT OF POWER OR PACKAGING!!!

\*\*\* ANY ADDITIONS, DELETIONS, OR OMISSIONS MUST BE CORRECTED ON THIS DRAWING AS THIS DRAWING WILL BE CONSIDERED ALL INCLUSIVE \*\*\*  
ALL GRAPHICS PROVIDED ARE FOR REFERENCE ONLY. IF CERTAIN DIMENSIONS ARE CRITICAL PLEASE VERIFY THOSE DIMENSIONS WITH YOUR SALESPERSON

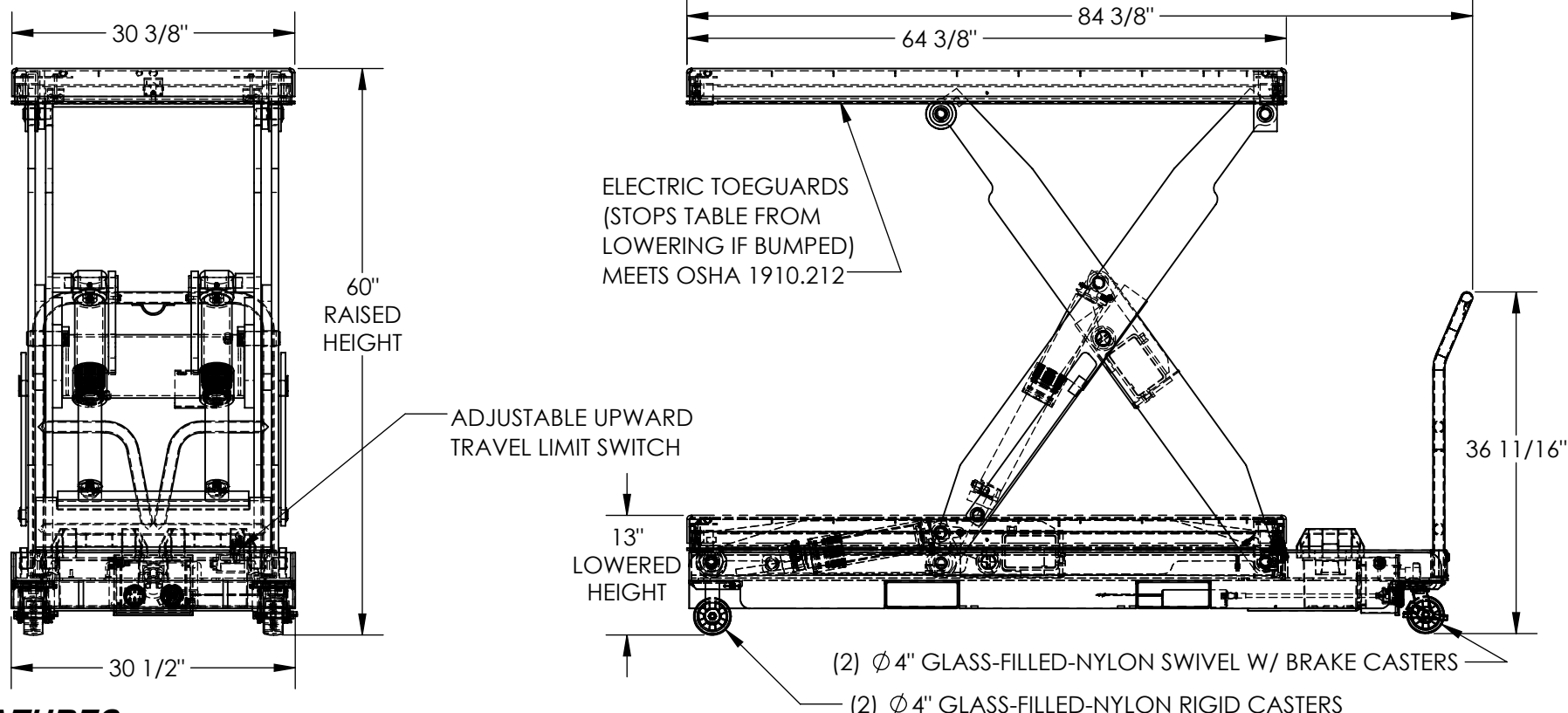

## STANDARD FEATURES

- MODEL NUMBER: **EHLTP-3064-3-60-D2**
- DECK WIDTH: 30 3/8"
- DECK LENGTH: 64 3/8"
- OVERALL LENGTH: 84 3/8"
- RAISED HEIGHT: 60"
- LOWERED HEIGHT: 13"
- MAX. CAPACITY: 3,000 LBS.
- TABLE CAPACITY (EVENLY DISTRIBUTED)
- SAFETY MAINTENANCE PROPS, DISPLACEMENT STYLE CYLINDERS INSTALLED ROD DOWN
- EMERGENCY SAFETY STOP HYDRAULIC FUSES IN ALL CYLINDERS
- DURABLE LIQUID PAINT BLUE FINISH
- CONTROL IS HANDHELD, 2 BUTTON, NEMA 4 PENDANT WITH MINIMUM 8' USABLE

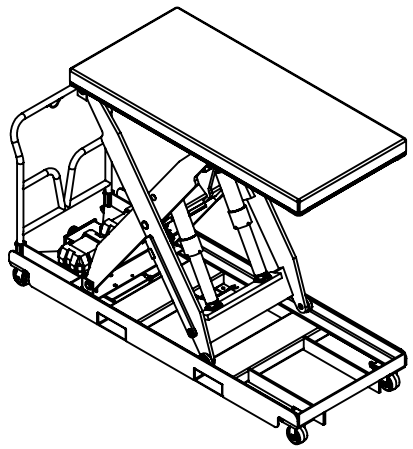

## SPECIAL FEATURES

NONE

|                     |  |  |
|---------------------|--|--|
| <b>APPROVAL</b>     | I, THE UNDERSIGNED, AGREE THAT THE PRODUCT AS REPRESENTED SATISFIES DESIGN AND DIMENSION REQUIREMENTS. I ALSO ACKNOWLEDGE MY DUTY TO CONFIRM PRODUCT AND INSTALLATION COMPLIANCE WITH ALL APPLICABLE FEDERAL, STATE AND LOCAL REGULATIONS AND STANDARDS. |  |
|                     | <b>UNITS REQUIRING APPROVAL DRAWINGS OR MODIFIED ARE NON-RETURNABLE</b>  |  |
|                     | [ ] As drawn [ ] As marked   |  |
|                     | Signed: _____  | Date: _____  |
| Printed Name: _____ |  | LEAD TIME WILL START UPON RECEIPT OF SIGNED APPROVAL DRAWING |

|                             |             |            |
|-----------------------------|-------------|------------|
| DISTRIBUTOR'S NAME:         |             | P.O.#      |
| <b>VESTIL MANUFACTURING</b> |             | X          |
|                             |             | W.O.#      |
| DRAWN BY: CRA               |             | X          |
| DATE: 10/20/2021            |             | SALES: X   |
| REFERENCE: X                | SCALE: 1:18 | FILE NAME: |
| QUOTED LEAD TIME: X         | QUOTE # X   | 01-007-472 |