

PORTABLE ELECTRIC HYDRAULIC LIFT TABLE - EHLTP-3064-1-60-D2

APPROX WEIGHT: 1072 lbs.
DOES NOT INCLUDE WEIGHT OF POWER OR PACKAGING!!!

*** ANY ADDITIONS, DELETIONS, OR OMISSIONS MUST BE CORRECTED ON THIS DRAWING AS THIS DRAWING WILL BE CONSIDERED ALL INCLUSIVE ***
ALL GRAPHICS PROVIDED ARE FOR REFERENCE ONLY. IF CERTAIN DIMENSIONS ARE CRITICAL PLEASE VERIFY THOSE DIMENSIONS WITH YOUR SALESPERSON

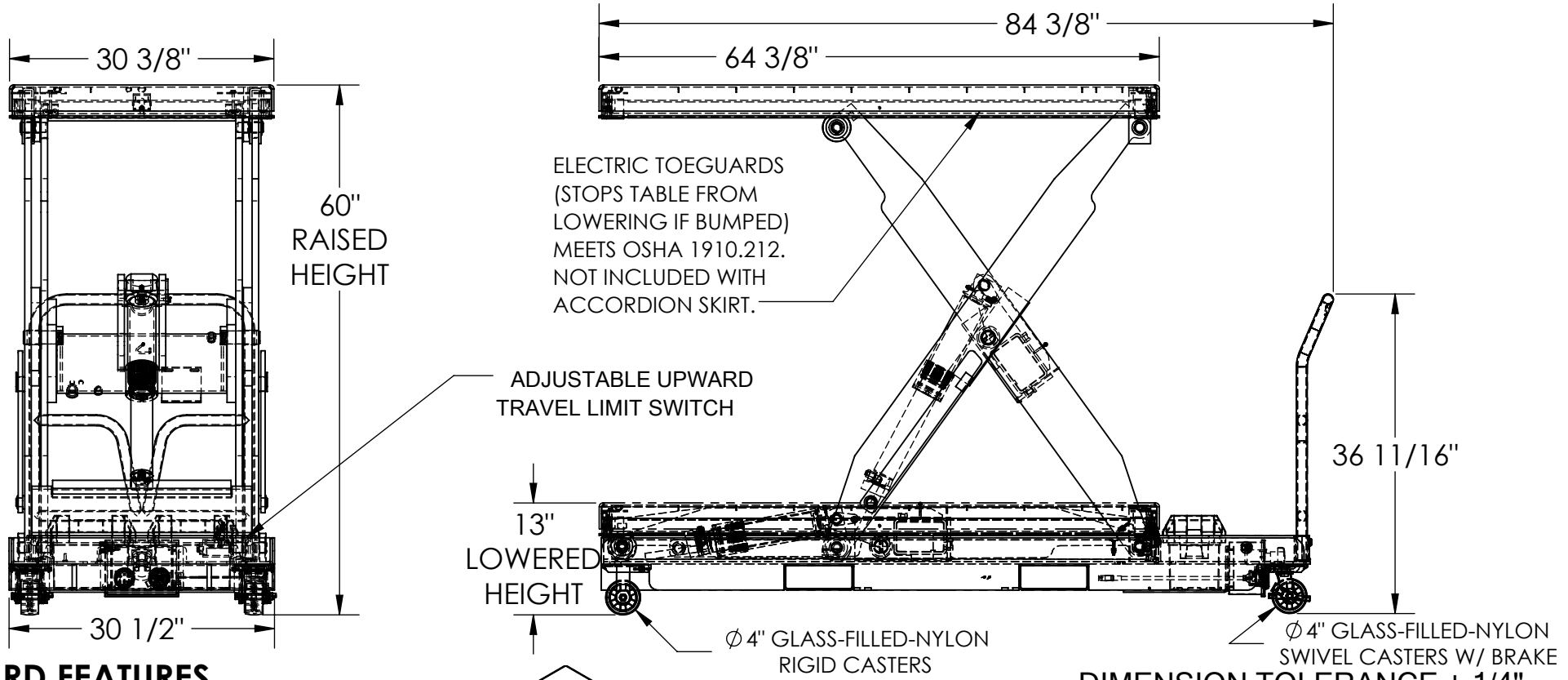

STANDARD FEATURES

- MODEL NUMBER: EHLTP-3064-1-60-D2
- DECK WIDTH: 30 3/8"
- DECK LENGTH: 64 3/8"
- OVERALL LENGTH: 84 3/8"
- RAISED HEIGHT: 60"
- LOWERED HEIGHT: 13"
- MAX. CAPACITY: 1,000 LBS.
- TABLE CAPACITY (EVENLY DISTRIBUTED)
- SAFETY MAINTENANCE PROPS, DISPLACEMENT STYLE CYLINDERS INSTALLED ROD DOWN EMERGENCY SAFETY STOP HYDRAULIC FUSES IN ALL CYLINDERS
- DURABLE LIQUID PAINT BLUE FINISH
- CONTROL IS HANDHELD, 2 BUTTON, NEMA 4 PENDANT WITH MINIMUM 8' USABLE COIL CORD
- 12 V DC WITH ONBOARD 115 CHARGER
- INTERNAL POWER UNIT

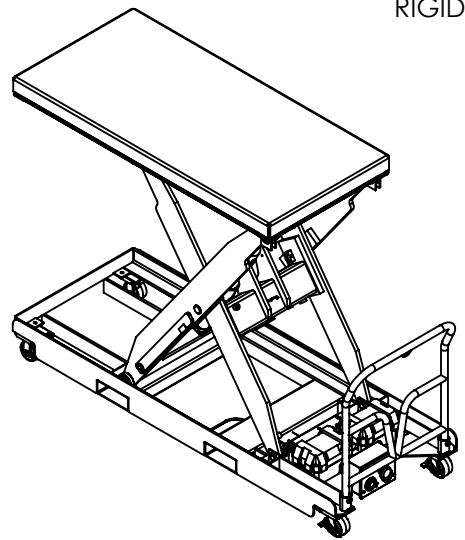

SPECIAL FEATURES

NONE

APPROVAL

I, THE UNDERSIGNED, AGREE THAT THE PRODUCT AS REPRESENTED SATISFIES DESIGN AND DIMENSION REQUIREMENTS. I ALSO ACKNOWLEDGE MY DUTY TO CONFIRM PRODUCT AND INSTALLATION COMPLIANCE WITH ALL APPLICABLE FEDERAL, STATE AND LOCAL REGULATIONS AND STANDARDS.

UNITS REQUIRING APPROVAL DRAWINGS OR MODIFIED ARE NON-RETURNABLE

[] As drawn [] As marked

Signed: _____ Date: _____

Printed Name: _____

LEAD TIME WILL START UPON RECEIPT OF SIGNED APPROVAL DRAWING

DISTRIBUTOR'S NAME:		P.O.#
VESTIL MANUFACTURING		-
		W.O.#
		-
DRAWN BY: CRA	DATE: 09/15/2020	SALES: -
REFERENCE: -	SCALE: 1:18	FILE NAME:
QUOTED LEAD TIME: -	QUOTE # -	01-007-460