

# LOW PROFILE DC POWERED HYDRAULIC SCISSOR LIFT CART - APPROX WEIGHT: 506 lbs. - DOES NOT INCLUDE WEIGHT OF POWER OR PACKAGING!!!

## CART-LP-2000-4242-DC

\*\*\* ANY ADDITIONS, DELETIONS, OR OMISSIONS MUST BE CORRECTED ON THIS DRAWING AS THIS DRAWING WILL BE CONSIDERED ALL INCLUSIVE \*\*\*  
 ALL GRAPHICS PROVIDED ARE FOR REFERENCE ONLY. IF CERTAIN DIMENSIONS ARE CRITICAL PLEASE VERIFY THOSE DIMENSIONS WITH YOUR SALESPERSON

**STANDARD:**  
 12V DC HYDRAULIC POWER UNIT  
 RAISED AND LOWERED BUTTONS  
 ARE ON TOP OF POWER UNIT  
 WITH ON BOARD CHARGER  
 AND HAND CONTROL

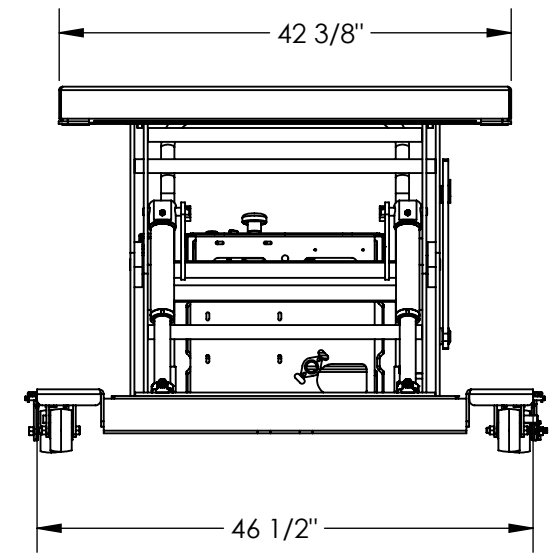
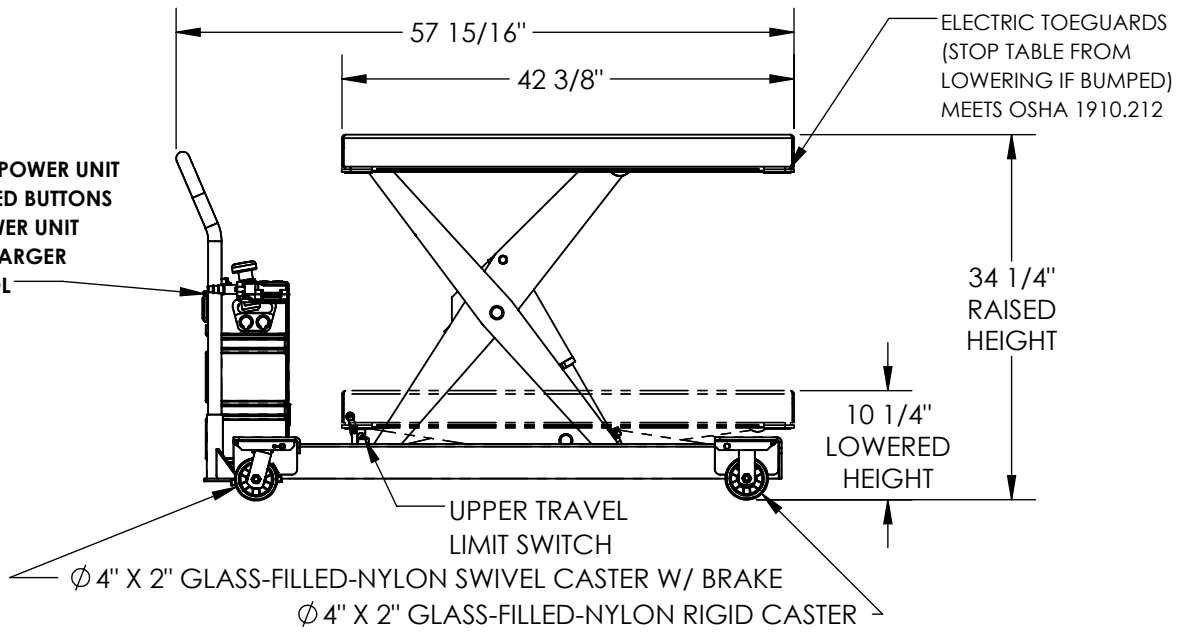

### STANDARD FEATURES

- MODEL NUMBER IS CART-LP-2000-4242-DC
- OVERALL WIDTH: 46 1/2"
- USABLE WIDTH: 42 3/8"
- OVERALL LENGTH: 57 15/16"
- USABLE LENGTH: 42 3/8"
- RAISED HEIGHT: 34 1/4"
- LOWERED HEIGHT: 10 1/4"
- 4" X 2" GLASS-FILLED-NYLON RIGID CASTER
- 4" X 2" GLASS-FILLED-NYLON SWIVEL CASTER W/ BRAKE
- TABLE CAPACITY (EVENLY DISTRIBUTED)
- MAX CAPACITY IS 2,000 LBS
- CONTROL IS HANDHELD 2 BUTTON, NEMA 4 PENDANT WITH MINIMUM 8' USABLE COIL CORD
- SAFETY MAINTENANCE PROPS, DISPLACEMENT STYLE CYLINDERS INSTALLED ROD DOWN
- EMERGENCY SAFETY STOP HYDRAULIC FUSES
- UPPER TRAVEL LIMIT SWITCH
- ELECTRIC PINCH POINT GUARD
- DURABLE LIQUID PAINT BLUE FINISH

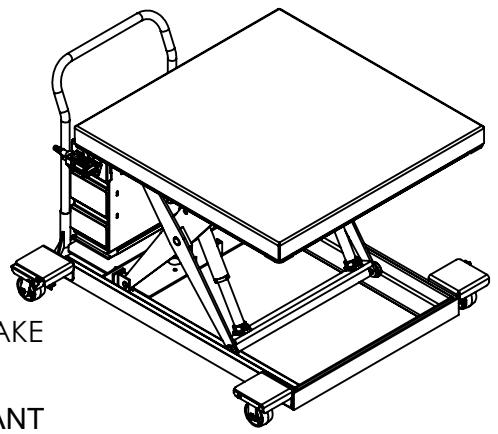

DECK TOLERANCE  $\pm 1/2"$   
 TABLE HEIGHT TOLERANCES  $\pm 1/2"$   
 DECK FLATNESS  $\pm 1/4"$

DIMENSION TOLERANCE  $\pm 1/4"$

**A P P R O V A L**

I, THE UNDERSIGNED, AGREE THAT THE PRODUCT AS REPRESENTED SATISFIES DESIGN AND DIMENSION REQUIREMENTS. I ALSO ACKNOWLEDGE MY DUTY TO CONFIRM PRODUCT AND INSTALLATION COMPLIANCE WITH ALL APPLICABLE FEDERAL, STATE AND LOCAL REGULATIONS AND STANDARDS.

**UNITS REQUIRING APPROVAL DRAWINGS OR MODIFIED ARE NON-RETURNABLE**

[ ] As drawn [ ] As marked

Signed: \_\_\_\_\_ Date: \_\_\_\_\_

Printed Name: \_\_\_\_\_

LEAD TIME WILL START UPON RECEIPT OF SIGNED APPROVAL DRAWING

### SPECIAL FEATURES

NONE

DISTRIBUTOR'S NAME:		P.O.#
VESTIL MANUFACTURING		X
DRAWN BY: CRA		DATE: 06/14/2019
REFERENCE: X		SCALE: 1:18
QUOTED LEAD TIME: X		QUOTE # X
		SALES: X
		FILE NAME: 01-007-403