

\*\*SPECIAL UNITS ARE NON-RETURNABLE  
 \*AVAILABLE AT ADDITIONAL COSTS

# STAINLESS STEEL HYDRAULIC ELEVATING CART, CART-1000-PSS

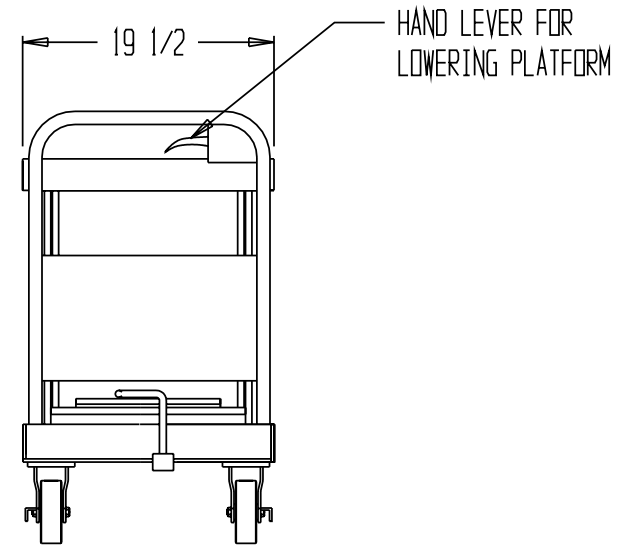
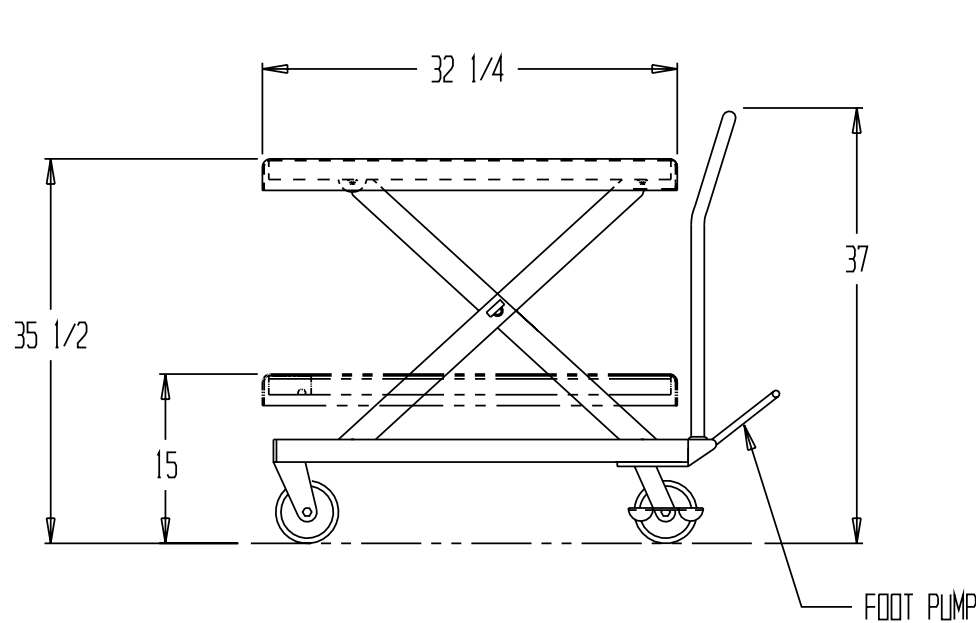

## STANDARD FEATURES

- MODEL NUMBER: CART-1000-PSS
- CAPACITY: 1,000 LBS.
- PLATFORM: 19 1/2" x 32 1/4"
- PLATFORM RAISED HEIGHT: 35 1/2"
- PLATFORM LOWERED HEIGHT: 15"
- STANDARD SINGLE SPEED FOOT PUMP

NOTE: SCISSOR LEGS, CASTERS, CASTER GUARDS, & PUMP ASSEMBLY ARE NOT STAINLESS STEEL.  
 SCISSOR LEGS & WHEEL GUARDS ARE PAINTED CARBON STEEL.  
 HANDLE IS CHROMED STEEL.

\*\*Any additions, deletions or omissions must be corrected on this drawing, as this drawing will be considered all inclusive.\*\*

## SPECIAL FEATURES

NONE

\*\*\* ALL GRAPHICS PROVIDED ARE FOR REFERENCE ONLY.  
 IF CERTAIN DIMENSIONS ARE CRITICAL PLEASE VERIFY  
 THOSE DIMENSIONS WITH YOUR SALESPERSON. \*\*\*

LEAD TIME WILL START UPON  
 RECEIPT OF SIGNED APPROVAL  
 DRAWING

## APPROVAL

I, the undersigned, hereby approve this print  
 As drawn       As marked  
 This includes my approval of design & dimensions.  
 Signed: \_\_\_\_\_  
 Date: \_\_\_\_\_

DISTRIBUTOR'S NAME:		P.O.#: -
		W.O.#: -
DRAWN BY: SR	DATE: 4-20-06	SALES: -
REFERENCE:	DRWG./FILE NAME:	
-	SCALE: NTS	CART-1000-PSS