



15F590

Wheel & Brake Changer



Building Quality Ground Support Products Since 1961

- Facilitates Wheel and Brake Disc Changes
- One-man operation, reduces man-hour requirement
- Will not interfere with gear jacks
- Eliminates necessity of lifting wheels, tires, or brake disc
- Services the following jet aircraft:
 - Boeing 707, 727, 737, 747, 757, 767, 777, 787
 - Douglas DC-8, DC-9, DC-10
 - Lockheed L-1011
 - Airbus A300/310, A318-A321, A330/340, A350, A380

15F590

Wheel & Brake Changer

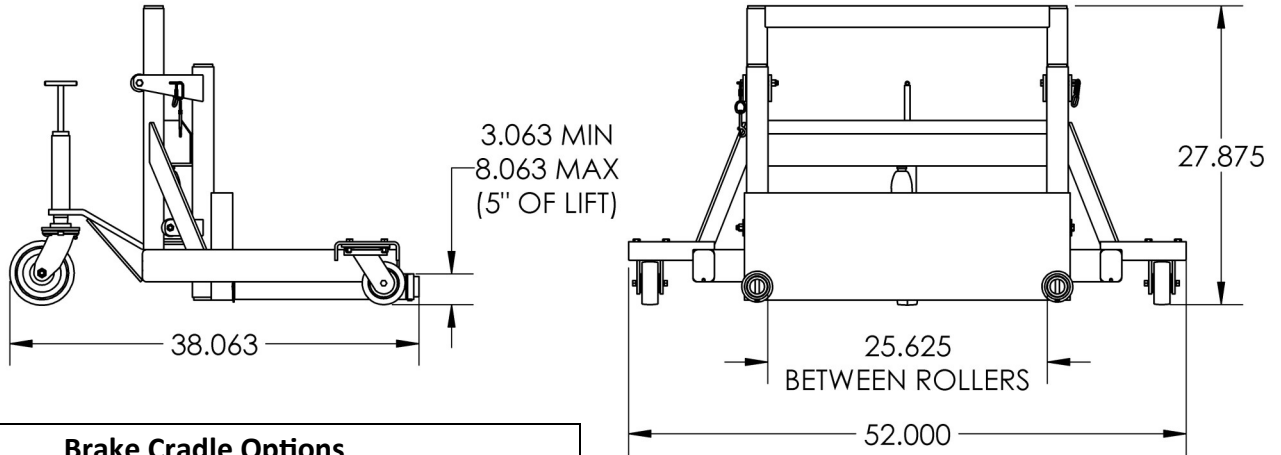

Brake Cradle Options

Main Gear Wheels	Nose Gear Wheels	Brake Cradle Model
F70, F100	N/A	15F389
A300, A310, B707, B727, B757, B767	A300, A310, B707, B757, B767	15F388
A319, A320, A321, B717, B737	N/A	15F388
DC8, DC9, MD80-90	DC8	15F388
A330, A340, A350, A380, B747, B777, B787, DC10, MD11, L1011	A330, A340, A350, A380, B747, B777, B787, DC10, MD11, L1011	15F679

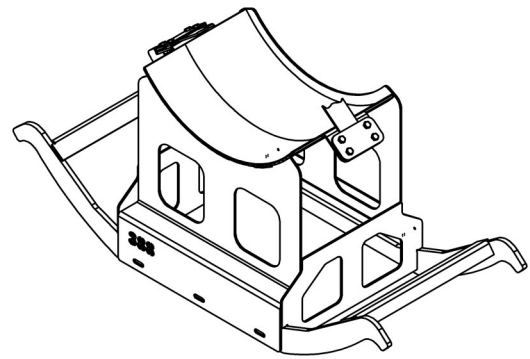

- Three Heavy Duty Casters
- Steel Rollers to support wheels, tires, or brake cradle and discs
- Hand operated screw jack to provide fore and aft tilt
- Hand operated hydraulic pump to provide vertical lift
- Durable powder coat finish
- Chain for securing wheel
- Storage box
- Max lift capacity - 750 lbs.

Shipping Dimensions - Crated

- 58" x 39" x 34"
- 440 lbs. (370 lbs. without cradle)

Shipping Dimensions - Pallet

- 54" x 48" x 34"
- 340 lbs. (270 lbs. without cradle)