



15F3165

# A318 A319 A320 A321 Towbar



Building Quality Ground Support Products Since 1961

- 8" x 15' high strength aluminum tube
- Fully retractable hydraulic running gear for adjustable height
- Safety lock system to avoid separation from aircraft
- Durable powder coat paint
- Quality shear bolts for aircraft protection
- Extra set of shear bolts included
- Solid tires
- Options:
  - Foam filled tires
  - Pneumatic tires
  - Cushioned lunette assembly
  - Spliced tube for easy transport

**15F3165**

# A318 A319 A320 A321 Towbar

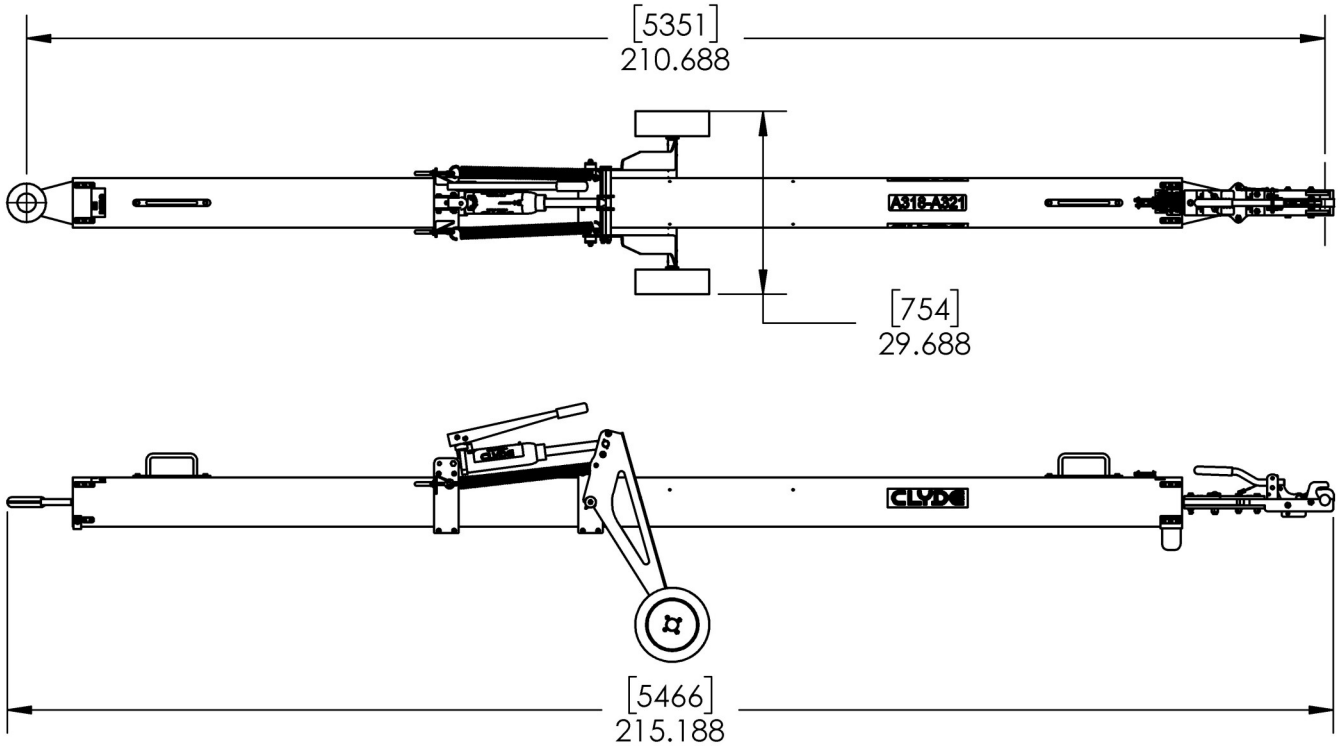

## Shipping Information

### Shipping Dimensions:

- Weight — 350 lbs.
- Length — 216"
- Width — 30"
- Height — 25"

### Crated Dimensions:

- Weight — 770 lbs.
- Length— 217"
- Width— 26"
- Height— 28"