

2-SHELF ALUMINUM SERVICE CART - SCA2-2840

APPROX WEIGHT: 97.99 lbs.
 DOES NOT INCLUDE WEIGHT OF POWER OR PACKAGING!!!

*** ANY ADDITIONS, DELETIONS, OR OMISSIONS MUST BE CORRECTED ON THIS DRAWING AS THIS DRAWING WILL BE CONSIDERED ALL INCLUSIVE ***
 ALL GRAPHICS PROVIDED ARE FOR REFERENCE ONLY. IF CERTAIN DIMENSIONS ARE CRITICAL PLEASE VERIFY THOSE DIMENSIONS WITH YOUR SALESPERSON

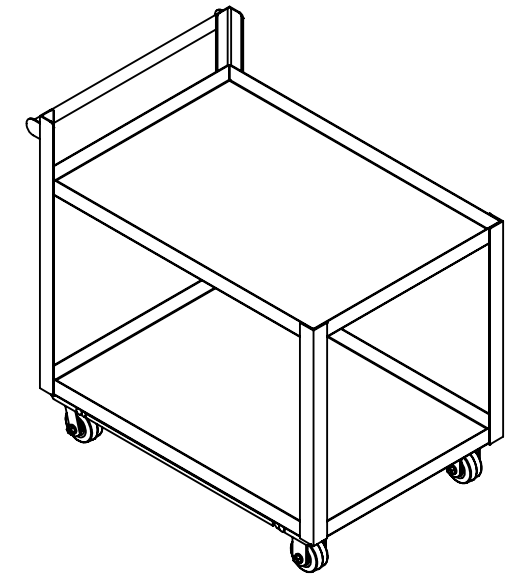
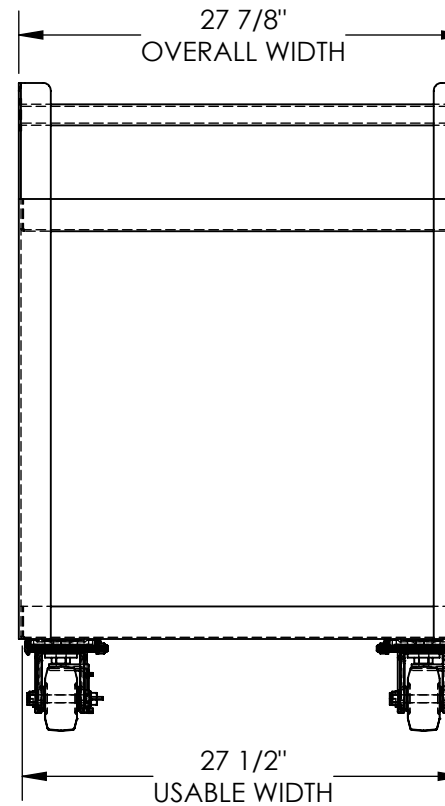
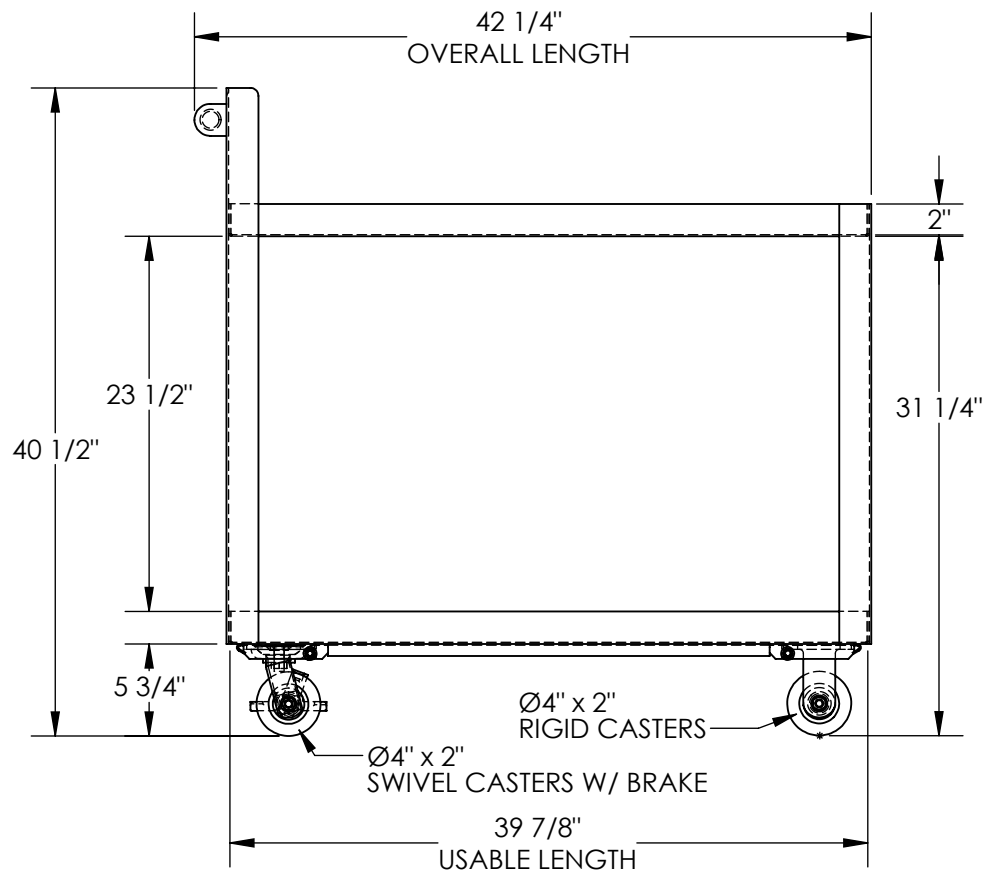

DIMENSION TOLERANCE ± 1/4"

STANDARD FEATURES

- MODEL NUMBER IS SCA2-2840
- CAPACITY IS 660 LBS. (330 LBS. PER SHELF)
- OVERALL WIDTH IS 27 7/8"
- USABLE WIDTH IS 27 1/2"
- OVERALL LENGTH IS 42 1/4"
- USABLE LENGTH IS 39 7/8"
- OVERALL HEIGHT IS 40 1/2"
- SHELF DEPTH IS 2"
- SHELF CLEARANCE IS 23 1/2"
- USABLE TOP SHELF HEIGHT IS 31 1/4"
- Ø4" X 2" MOLD-ON-RUBBER CASTERS
- 2- RIGID CASTERS
- 2- SWIVEL CASTERS W/ BRAKE
- ALUMINUM FRAME CONSTRUCTION

SPECIAL FEATURES

NONE

APPROVAL

I, THE UNDERSIGNED, AGREE THAT THE PRODUCT AS REPRESENTED SATISFIES DESIGN AND DIMENSION REQUIREMENTS. I ALSO ACKNOWLEDGE MY DUTY TO CONFIRM PRODUCT AND INSTALLATION COMPLIANCE WITH ALL APPLICABLE FEDERAL, STATE AND LOCAL REGULATIONS AND STANDARDS.

UNITS REQUIRING APPROVAL DRAWINGS OR MODIFIED ARE NON-RETURNABLE

[] As drawn [] As marked

Signed: _____ Date: _____

Printed Name: _____

LEAD TIME WILL START UPON RECEIPT OF SIGNED APPROVAL DRAWING

DISTRIBUTOR'S NAME:		P.O.#
VESTIL MANUFACTURING		X
DRAWN BY: CA		W.O.#
DATE: 3/27/2015		X
REFERENCE: X	SCALE: 1:12	SALES: X
QUOTED LEAD TIME: X	QUOTE #	FILE NAME:
	X	32-007-002