



15F3619

Spiral Stand



Building Quality Ground Support Products Since 1961

- 500 lb. platform capacity
- Foot actuated hydraulic pump
- Hydraulic restrictors in case of pressure failure
- Non-slip self-cleaning steps with non-slip steel tread grip platform floor
- 4" O.D. non-marring bumpers
- Towbar actuated parking brake
- Fixed and swivel casters with 16" dia. solid tires
- Stairs and platform stay parallel at any height position
- Durable powder coat finish

15F3619

Spiral Stand

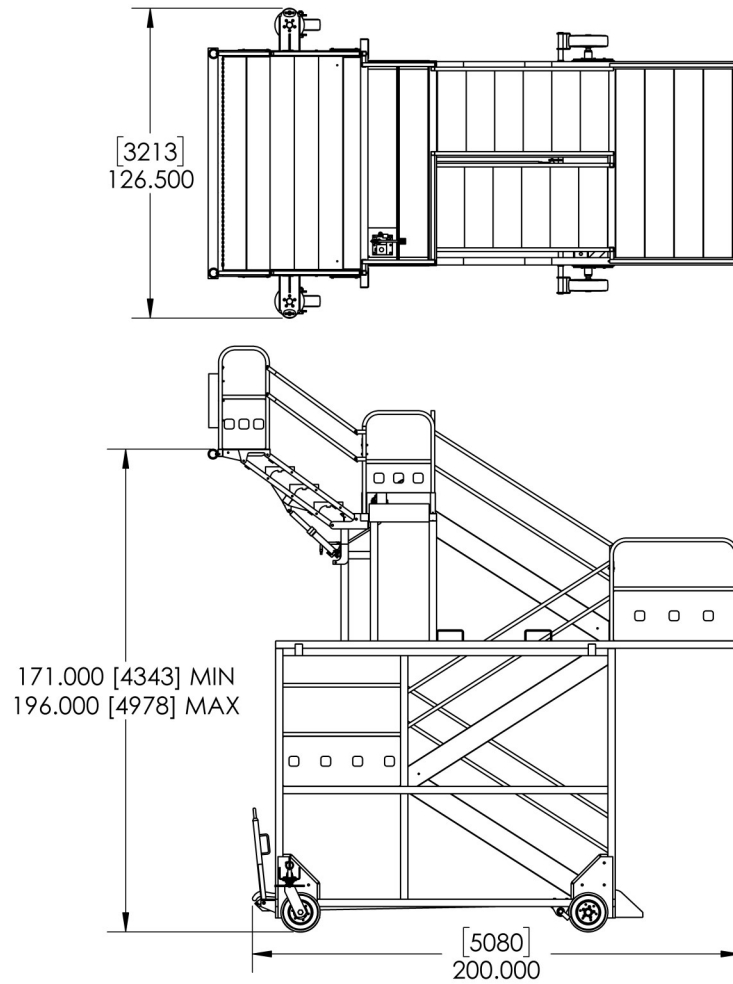

Shipping Information

- Dimensions:
 - Weight - 5,575 lbs.
 - Ships in 3 sections