



15F3510

# Radome Maintenance Stand



## Building Quality Ground Support Products Since 1961

- Designed to safely access crown of all narrow body aircraft
- Contoured hydraulically adjustable cage to match narrow body fuselage
- 750 lb. platform capacity, 2,500 lbs. overall
- Hydraulically elevates 186.5" to 300"
- Double acting hydraulic hand pump with two 2" dia. x 35" stroke lift cylinders, plus an air over hydraulic system
- Hydraulic restrictors in case of pressure failure
- Safety strut with pins
- Non-slip steel grip-strut steps
- Two fall arrest anchor points in upper platform
- Fixed rear and swivel front casters provide ease in maneuverability.
- Hand adjustable screw jacks on each corner for stability
- Drop down pole to tow stand
- 16" diameter solid tires
- Optional:
  - 12 volt work light pkg.
  - Safety mesh on contoured cage
  - Saloon style entry doors in upper platform

# 15F3510

## Radome Maintenance Stand

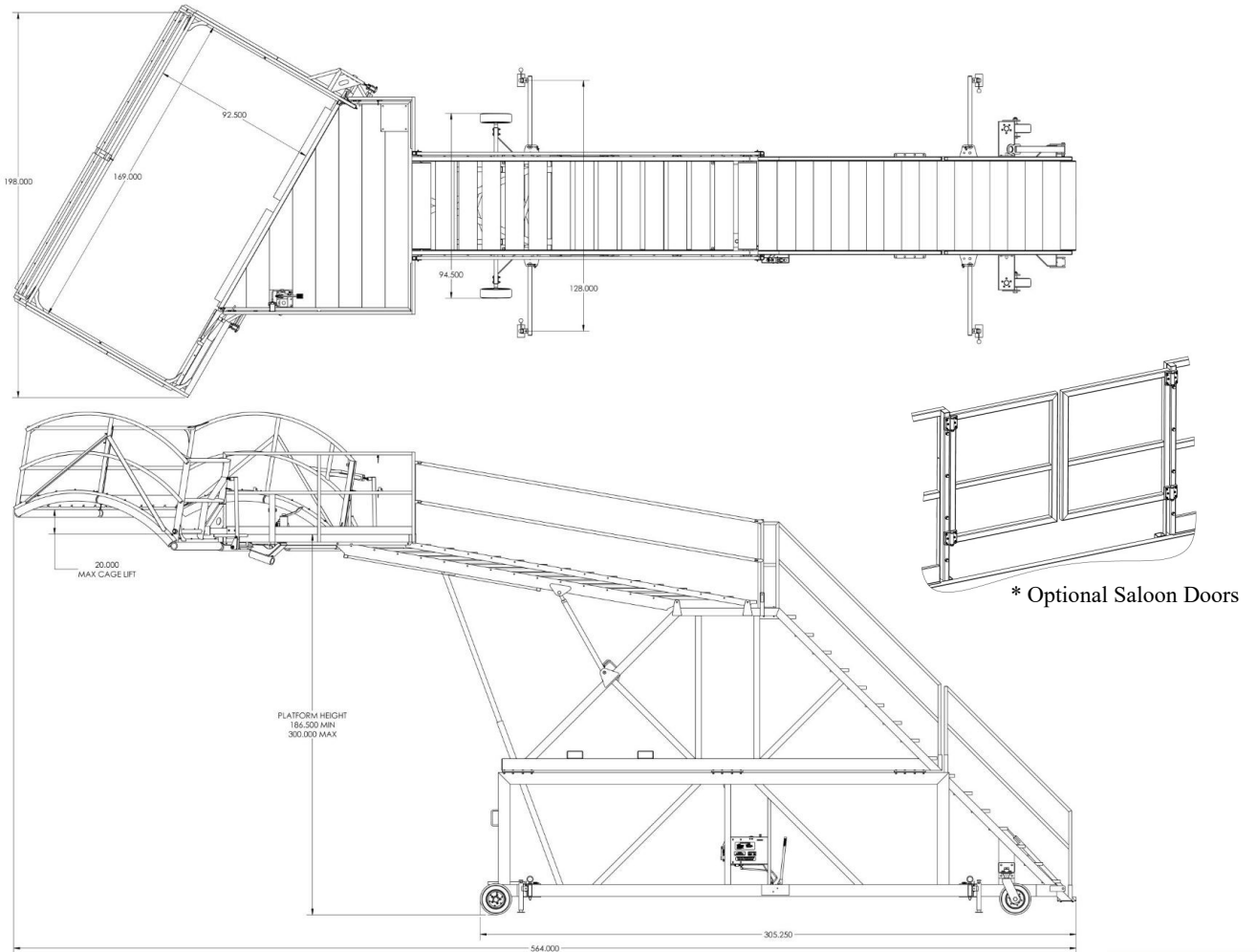

### Shipping Information

- Dimensions:
  - Weight - 8,000 lbs.
  - Shipping length - 53'
  - Ships in 3 pieces (53' step deck with required riser or load leveler)