



15F2011

Maintenance Stand



Building Quality Ground Support Products Since 1961

- 500 lb. platform capacity
- Adjustable to any height within its 7' to 15' platform floor range
- Double acting hydraulic hand pump
- Hydraulic restrictors in case of pressure failure
- Safety strut with pin
- Non-slip, self-cleaning steps and platform floor
- Heavy-duty casters and 16" dia. solid tires
- Hand adjustable screw jacks for stability
- Stair and platform railings can be lifted out and stored on the base
- Base, stairs, and platform stay parallel at any height position
- 4" O.D. non-marring rubber bumper at the leading edge of the platform
- Durable powder coat finish
- Options:
 - 4.00 x 8 pneumatic tires
 - 4.00 x 8 foam filled tires
 - Large Caster Option

15F2011

Maintenance Stand

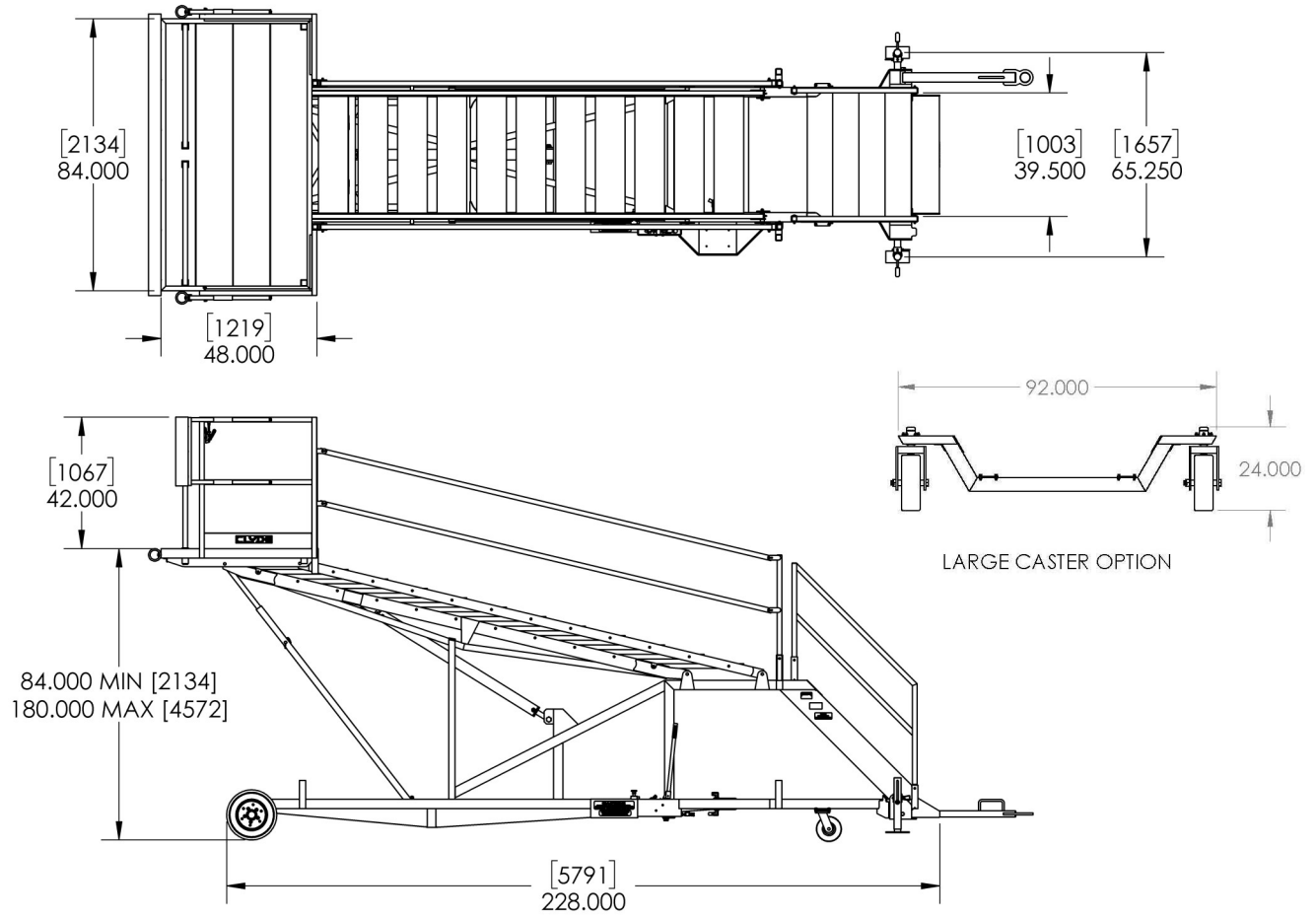

Shipping Information

- Dimensions:
 - Weight - 2070 lbs.
 - Length - 255"
 - Width - 93"
 - Height - 104"