



**15F3065**

# Maintenance Stand



**Building Quality Ground Support Products Since 1961**

- An updated, improved version of the long time standard B-5 used by the Military
- 500 lb. capacity
- Working height of 88"- 138"
- Foot actuated hydraulic pump
- 8" Heavy duty swivel casters with brakes and swivel locks
- Platform size of 30" x 76"
- Drop down pole to tow stand
- Durable powder coat finish

# 15F3065

## Maintenance Stand

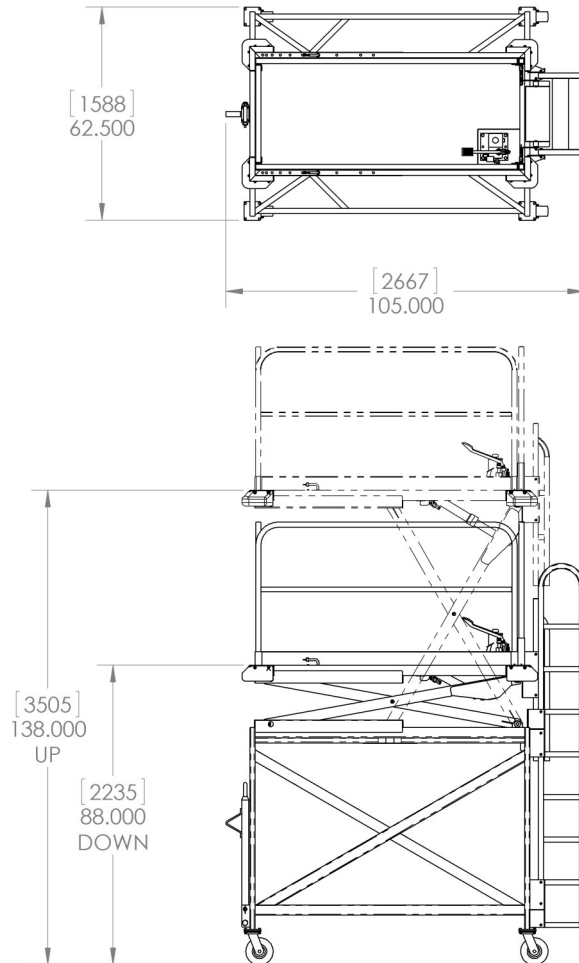

### Shipping Information

- Dimensions:
  - Weight - 1250 lbs.
  - Length - 105"
  - Width - 63"
  - Height - 101"