



**15F3060**

# Maintenance Stand



**Building Quality Ground Support Products Since 1961**

- An updated, improved version of the long time standard B-4 used by the Military
- 500 lb. capacity
- Working height of 36"- 86"
- Foot actuated hydraulic pump
- 8" Heavy duty swivel casters with brakes and swivel locks
- Platform size of 30" x 76"
- Drop down pole to tow stand
- Durable powder coat finish

# 15F3060

## Maintenance Stand

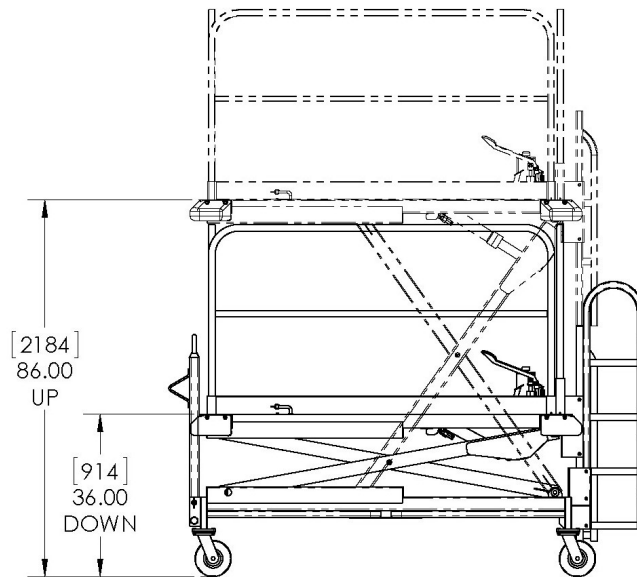
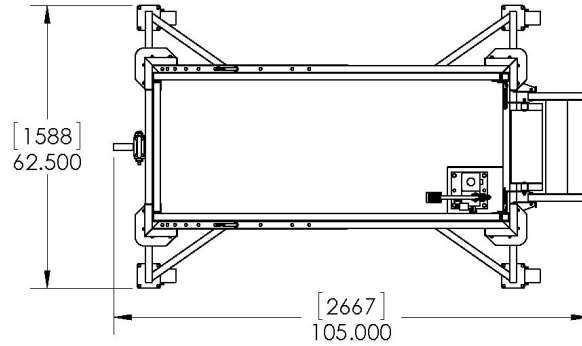

### Shipping Information

- Dimensions:
  - Weight - 1000 lbs.
  - Length - 105"
  - Width - 63"
  - Height - 78"