

15F3254

OWNER'S MANUAL

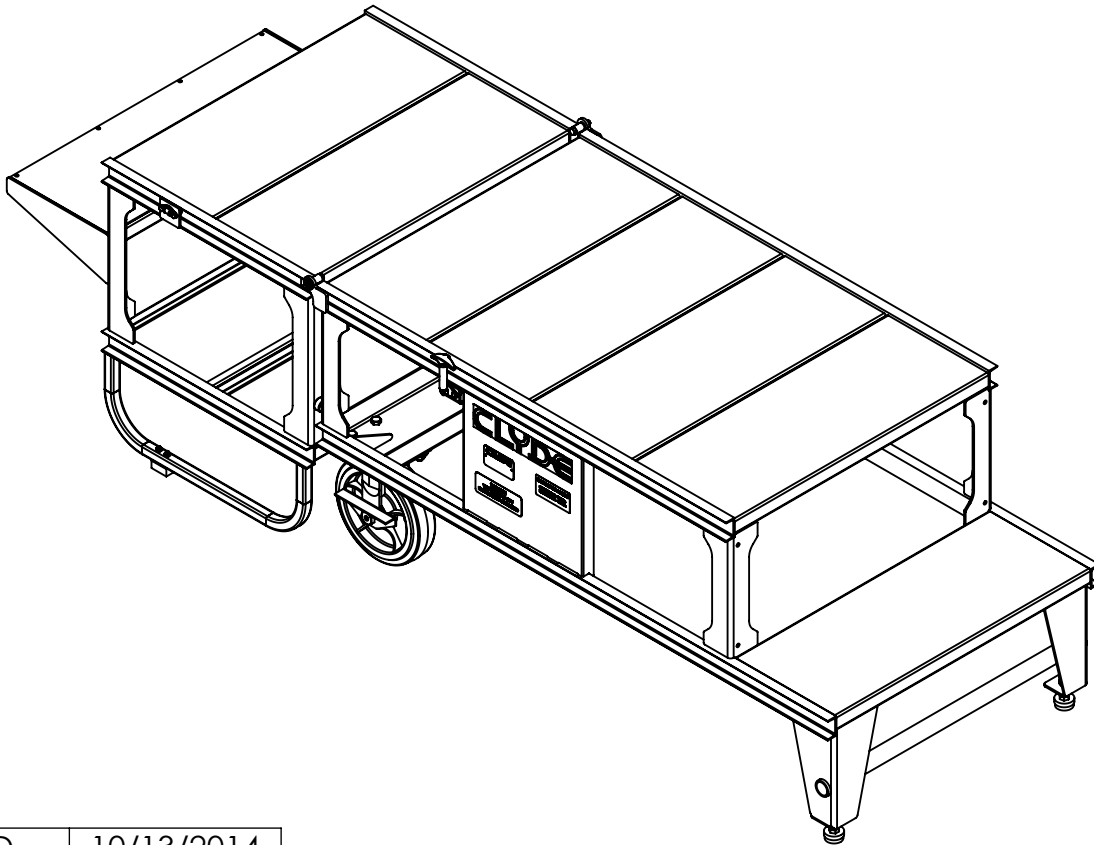

ISSUED	10/13/2014
REVISED	8/17/2016
REVISED	11/21/2016
REVISED	11/21/2019

LOW LEVEL FOLDING STAND

WARRANTY

Clyde Machines Inc. warrants all goods of its manufacture to be free from defects caused by faulty material or poor workmanship and will at its option repair or replace, without charge, or allow credit for any such goods found on examination by Seller to be defective under normal use and service within one year from date of shipment to the Buyer, provided Seller is promptly notified in writing upon discovery of such defects. Goods shall not be returned to Seller or modified at Seller's expense without Seller's consent in writing. This warranty does not cover damage caused by improper use, installation, overloading, accident, neglect or harmful alterations or repairs made by others, weather conditions and acts of God. The Buyer's remedies with respect to defective good shall be exclusively limited as above provided and in no event shall the Seller be liable for consequential damage. Components purchased by the Seller are subject to the warranty policy of the original equipment manufacturer, and Seller will assist the Buyer in resolving any warranty claims if such action is required.

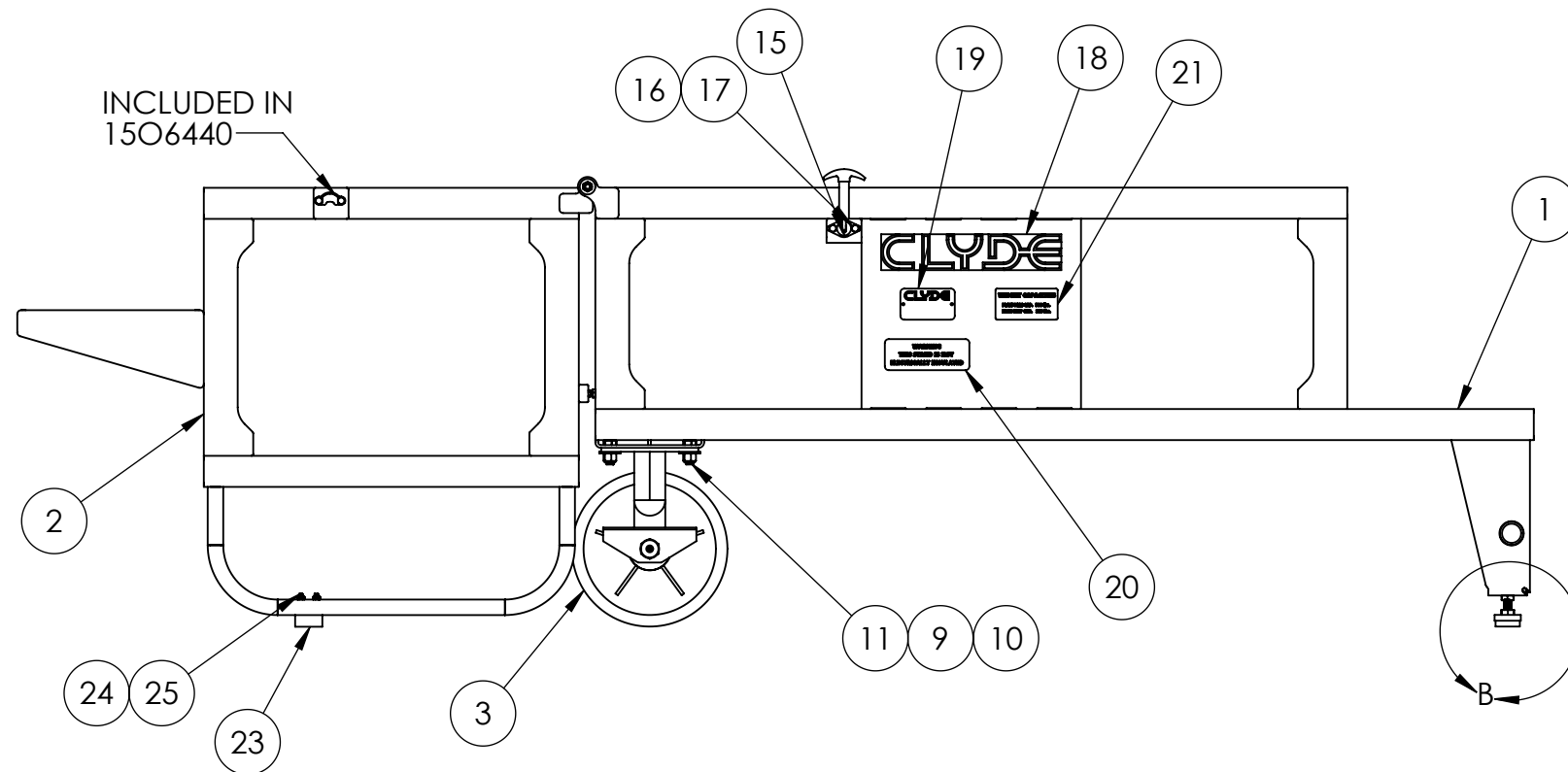
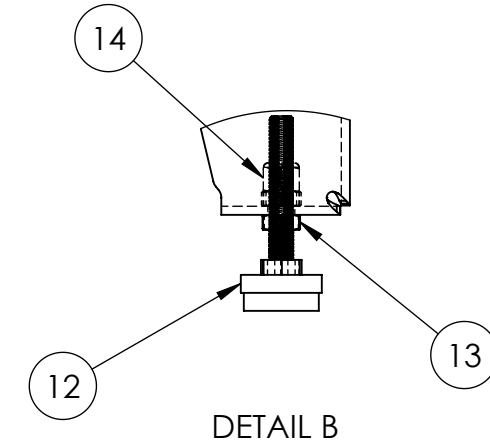
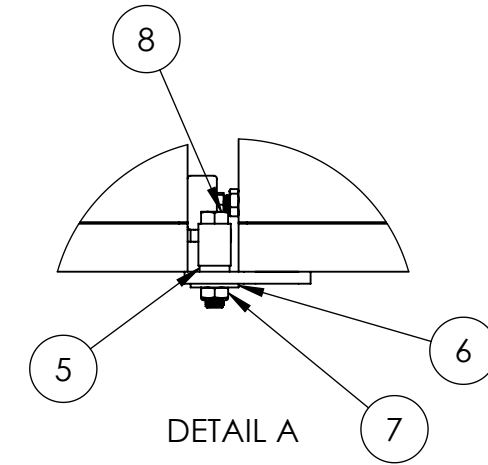
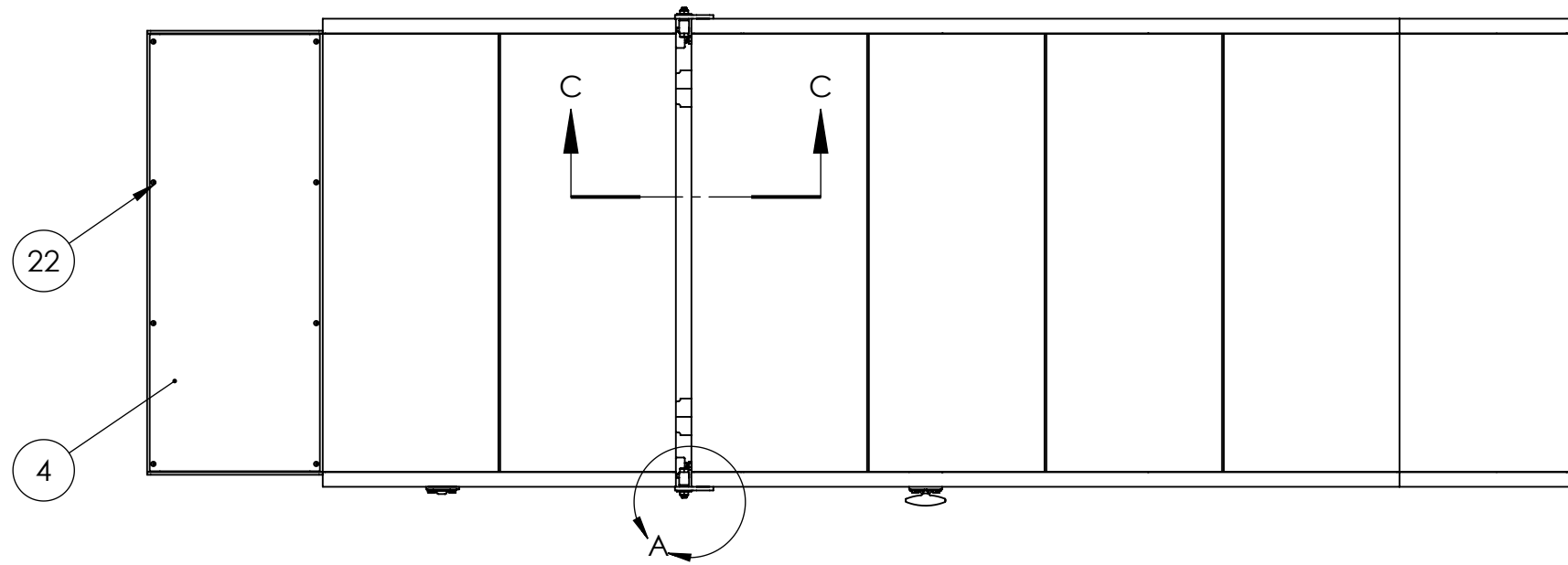

INCLUDED IN
15O6440

CLYDE

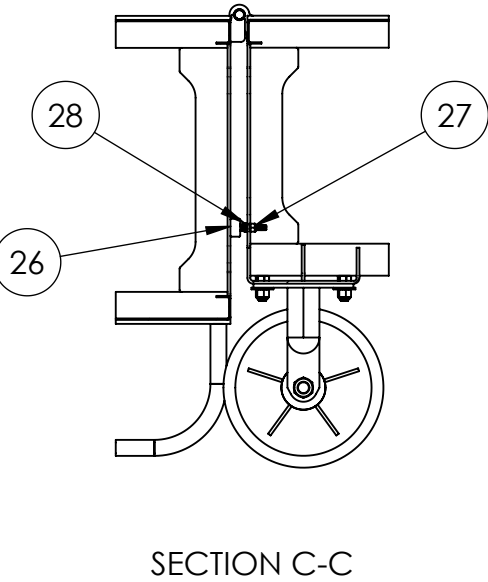

15F3254 ASSEMBLY

ITEM NO.	PART NUMBER	QTY.	DESCRIPTION	
	1	15W6444	1	BASE FRAME WELD
	2	15W6445	1	PLATFORM WELD
	3	15O6438	2	RIDGID CASTER W/BRAKE
R	4	15L26239	1	STEP CAP
	5	15L14429	2	STEP SPACER
	6	15O246	2	3/8" WASHER
	7	15O3400	2	3/8-24 NYLOK JAM NUT
	8	15O719	2	3/8-24 x 1-3/4" LG. C.S.
	9	15O255	8	1/2" WASHER
	10	15O586	8	1/2-20 NYLOK NUT
	11	15O635	8	1/2-20 x 1-1/4" LG. C.S.
R	12	15O6439	2	FOOT PAD
R	13	15O1241	2	1/2-13 UNC JAM NUT
R	14	15O1718	2	1/2-13 UNC NYLOK NUT
	15	15O6440	1	DRAW LATCH
	16	15O298	4	1/4-28 NYLOK NUT
	17	15O304	4	1/4-28 x 3/4" LG. C.S.
	18	15O	2	CLYDE LOGO
	19	15O4099	1	SERIAL NUMBER PLATE
	20	15L16864	1	WARNING PLACARD
	21	15O6208	1	PLACARD, CAPACITY
R	22	15O1425	8	POP RIVET, 1/8" ALUMINUM
R	23	15O6700	2	BUMPER
R	24	15O1689	4	1/4-28 NYLOK JAM NUT
R	25	15O6701	4	1/4-28 x 1-1/2" SCKT HEAD CS ZP
R	26	15O7048	2	ADJUSTABLE PAD
R	27	15O578	2	5/16-18 NYLOK NUT
R	28	15O1948	2	5/16-18 UNC JAM NUT